

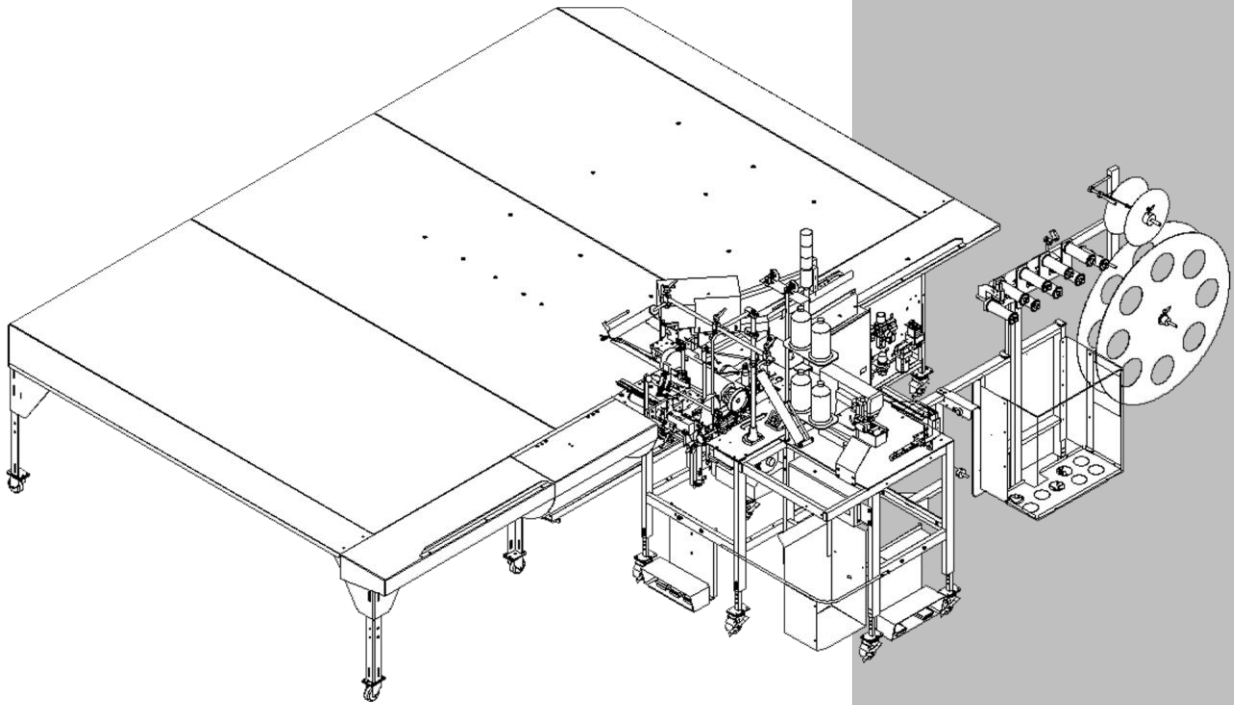

Model **1335AS**

Revision 3 Updated Feb 29, 2012

# Technical Manual & Parts Lists



From the library of: Diamond Needle Corp

**Atlanta Attachment Company**

362 Industrial Park Drive

Lawrenceville, GA 30046

770-963-7369 • [www.atlatt.com](http://www.atlatt.com)





# ATLANTA ATTACHMENT COMPANY, INC.

## Confidential and Proprietary Information

The materials contained herein are confidential and proprietary information of Atlanta Attachment Company. In addition to any confidentiality and non-disclosure obligations that currently exist between you and Atlanta Attachment Company, your use of these materials serves as an acknowledgment of the confidential and proprietary nature of these materials and your duty not to make any unauthorized use or disclosure of these materials.

All materials contained herein are additionally protected by United States Copyright law and may not be used, disclosed, reproduced, distributed, published or sold without the express written consent of Atlanta Attachment Company, which consent may be withheld in Atlanta Attachment Company's sole discretion. You may not alter or remove any copyright, trademark or other notice from copies of these materials.

## Patents & Patents Pending

The sale of this product does not sell or otherwise transfer any license or other rights under any U.S. Patent or other corresponding foreign patent.

This equipment is manufactured under one or more of the following patents:

4,280,421 • 4,432,294 • 4,466,367 • 4,644,883 • 5,134,947 • 5,159,889 • 5,203,270 • 5,373,798 •  
5,437,238 • 5,522,332 • 5,524,563 • 5,562,060 • 5,634,418 • 5,647,293 • 5,657,711 • 5,743,202 •  
5,865,135 • 5,899,159 • 5,915,319 • 5,918,560 • 5,924,376 • 5,979,345 • 6,035,794 • 6,055,921 •  
6,202,579 • 6,279,869 • 6,295,481 • 6,494,225 • 6,523,488 • 6,574,815 • 6,802,271 • 6,834,603 •  
6,968,794 • 6,994,043 • 7,543,364 • 7,574,788 • 7,647,876 • 7,735,439

Foreign Patents: 9-520,472 • 0,537,323 • 92,905,522.6 • 96,936,922.2 • 2,076,379 • 2,084,055

Other U.S. and Foreign Patents Pending.

# Contents

Important Safety Instruction .....	1
Mandatory Information .....	1
Scope of the Instruction Material.....	1
Intended Use .....	1
Exclusion of Misuse.....	1
Liability.....	2
Choice and Qualification of Personnel .....	2
Training.....	2
Responsibilities.....	2
A Word to the Operator .....	3
Safety Equipment on the Machines .....	3
Damage .....	3
Faults or Errors .....	3
Signs on the Machine.....	3
Protective Eyewear .....	4
Tools .....	4
Oils, Lubricants, Chemicals.....	4
No Smoking, Fire, Explosion Hazard.....	4
Workplace.....	4
Emergency STOP.....	4
First Aid .....	4
Important Notices.....	5
Reporting and Fighting Fires .....	5
Electrical Power Supply.....	5
Delivery of the Machine/Packaging.....	6
Transport Damage.....	6
Interim Storage.....	6
Transporting the Machine .....	6
Workplace Environment .....	7
Local Regulations .....	7
Maintenance .....	7
General Safety Instructions.....	7
Maintenance, Care, Adjustment.....	7
Waste, Disassembly, Disposal .....	7
Repair .....	8
Replacement Parts.....	8

Repair, Electrical.....	8
Ventilation/Hazardous Gases.....	8
Hydraulic and Pneumatic Systems.....	8
General Liability.....	9
Starting Machine Movements.....	9
A Word to the End User.....	9
Safety Precautions.....	10
General Machine Data.....	11
Physical Dimensions.....	11
Touch-Screen Operation.....	11
Light Tower Functions.....	12
Basic Machine Operation.....	12
Loading the Gusset Roll And Accumulator.....	12
Loading and Adjusting the Folders.....	12
Adjusting the Active Edge Guiding.....	13
Starting the Automatic Cycle.....	13
Making Adjustments to Settings.....	14
Finishing the Panel.....	15
Adjusting the Corner Ruffles.....	15
Settings Menus.....	16
Styles.....	18
Creating A New Style.....	18
Recalling A Style.....	18
Editing an Existing Style.....	19
Copying an Existing Style.....	19
General Machine Adjustments.....	20
Electric Eye Sensor Adjustment.....	20
Reflective Tape Maintenance.....	20
Sewing Head and Motor.....	21
Ruffler Drive Assembly.....	21
Folder Assembly.....	22
Edge Guide Assembly.....	22
Rotator Assembly.....	23
Puller Assembly.....	23
Knife Assembly.....	24
Rear Conveyor Assembly.....	24
Accumulator Assembly.....	24

## Technical Manual & Parts Lists

---

1334 Auto Flanging Unit .....	25
Sequence of Operation .....	25
11335AS88A Recommended Spare Parts List .....	25
AAC Part # SP1335AS88A Spare Parts Kit .....	25
Maintenance .....	26
Cleaning Electric Eyes and Sensors .....	27
Assembly Drawings & Parts Lists .....	30
11335AS88A Auto Pillowtop Ruffler w/Flange, Flat Style .....	31
1335-120 Puller Drive Assembly .....	32
1335-139 Clamp & Switch Assembly .....	33
1335A-10 Sewing Head Assembly .....	34
1335A-200 Rotate Assembly .....	36
1335A-300 Folder Assembly .....	38
1335B-301 Folder Slide/Pivot Assembly .....	40
1335A-400 Table, Stand & Motor Assembly .....	42
1335A-425 Console Assembly .....	44
1335A-430 Guide Roller Assembly .....	45
1335A-910 Main Solenoid Panel Assembly .....	46
1335A-600 Rear Conveyor Assembly .....	48
1335Q-02A Ruffler Drive Assembly .....	50
1335Q-110 Footlift Assembly .....	51
1335Q-450 Thread Pull-off Assembly .....	52
1335Q-460 Tension Opener Assembly .....	53
1335Q-900A Main Electrical Panel, Mod. ....	54
132556-215 Rotate Sub-Assembly .....	56
132556-270 Front Clamp Assembly .....	58
132556-500C Edge Guide Assembly .....	60
132556-520 Edge Guide Assembly .....	61
33001130A Light Tower Assembly .....	62
1335140 Puller Assembly .....	64
97-1700A Touch Screen Assembly .....	65
1334-1000A Sew Head Assembly .....	66
11334QY28A Auto Flanging Module .....	68
1334-1100C Folder Mount Assembly .....	69
1334-3000 Control Panel Assembly .....	70
1334-2000 Frame Assembly .....	72
1334-2500 Accumulator Frame Assembly .....	74

1335Q-800A Accumulator Assembly.....	76
132556-011 Dual Foot Pedal Assembly .....	77
1335050 Leg Assembly .....	78
1335000 Air Table Assembly .....	80
1335000INS1 .....	81
1335000INS2 .....	82
1335000INS3 Left Air Table Assembly.....	83
1335000INS4 Right Air Table Assembly.....	84
1335000INS5 Air Table Assembly.....	85
1335-0167 Duct Assembly .....	86
1335-905 Stepper Box Adjustments .....	87
1335130 Trap Door Assembly.....	88
1335-0190 Blower Box Assembly.....	90
1334-PD1 Pneumatic Diagram .....	91
1335Q-PD2 Pneumatic Diagram .....	92
1334-3000WD1 Wiring Diagram .....	93
1335-900AWD1 Wiring Diagram .....	94
1335Q-900AWD1 Wiring Diagram .....	95
1335Q-900AWD2 Wiring Diagram .....	96
1335Q-910AWD3 Wiring Diagram .....	97
Appendix A.....	98
Finishing the Gusset.....	98
Loading the Accumulator .....	98
Loading the Folder.....	99
Corner Ruffle .....	100
Appendix B .....	100
Accumulator.....	100
Rear Conveyor .....	101
Edge Guide.....	101
Folder .....	102
Footlift.....	102
Sewing Head .....	103
Knife .....	103
Rotator.....	104

## Important Safety Instruction



This part of the Instruction Material is provided for the safe use of your equipment. It contains important information to help work safely with the unit and describes the dangers inherent in machinery. Some of these dangers are obvious, while others are less evident.

### Mandatory Information

All persons operating and/or working on the 1335AS88A Pillowtop Gussett Ruffler with Flat Style Flange should read and understand all parts of the Safety Instructions. This applies, in particular, for persons who only operate and/or work on the unit occasionally (e.g. for maintenance and repair). Persons who have difficulty reading must receive particularly thorough instruction.

### Scope of the Instruction Material

- The Instruction Material comprises:
- Safety information
- Operator Instructions
- Electrical and Pneumatic diagrams

And may also include;

- A list of recommended spare parts
- Instruction Manual(s) for components made by other manufacturers
- The layout and installation diagram containing information for installation

### Intended Use

Our machines are designed and built in line with the state of the art and the accepted safety rules. However, all machines may endanger the life and limb of their users and/or third parties and be damaged or cause damage to other property, particularly if they are operated incorrectly or used for purposes other than those specified in the Instruction Manual.

### Exclusion of Misuse



Non-conforming uses include, for example, using the equipment for something other than it was designed for, as well as operation without duly installed safety equipment. The risk rests exclusively with the end user.

Conforming use of the machine includes compliance with the technical data, information and regulations in all parts of the complete Instruction Material, as well as compliance with the maintenance regulations. All local safety and accident prevention regulations must also be observed.

## Liability

The machine should only be operated when in perfect working order, with due regard for safety and the potential dangers, as well as in accordance with the Instruction Material. Faults and malfunctions capable of impairing safety should be remedied immediately. We cannot accept any liability for personal injury or property damage due to operator errors or non-compliance with the safety instructions contained in this booklet. The risk rests exclusively with the end user.

The Instruction Material should always be kept near the machine so that it is accessible to all concerned.

The local, general, statutory and other binding regulations on accident prevention and environmental protection must also be observed in addition to the Instruction Material. The operating staff must be instructed accordingly. This obligation also includes the handling of dangerous substances and provision/use of personal protective equipment.

The Instruction Material should be supplemented by instructions, including supervisory and notification duties with due regard for special operational features, such as the organization of work, work sequences, the personnel deployed, etc.

The personnel's awareness of the dangers and compliance with the safety regulations should be checked at irregular intervals.

## Choice and Qualification of Personnel

Ensure that work on the machine is only carried out by reliable persons who have been appropriately trained for such work - either within the company, by our field staff or at our office - and who have not only been duly appointed and authorized, but are also fully familiar with the local regulations. Work on the machine should only be carried out by skilled personnel, under the management and supervision of a duly qualified engineer.

This not only applies when the machine is used for production, but also for special work associated with its operation (start-up and maintenance), especially when it concerns work on the hydraulic or electrical systems, as well as on the software/serial bus system.

## Training

Everyone working on or with the machine should be duly trained and informed with regard to correct use of the safety equipment, the foreseeable dangers which may arise during operation of the machine and the safety precautions to be taken. In addition, the personnel should be instructed to check all safety mechanisms at regular intervals.

## Responsibilities

Clearly define exactly who is responsible for operating, setting-up, servicing and repairing the machine. Define the responsibilities of the machine operator and authorize him to refuse any instructions by third parties if they run contrary to the machine's safety. This applies in particular for the operators of machines linked to other equipment. Persons receiving training of any kind may only work on or with the machine under the constant supervision of an experienced operator. Note the minimum age limits permitted by law.

## A Word to the Operator

The greatest danger inherent in our machines: is that of fingers, hands or loose clothing being drawn into a machine by live, coasting or rotating tools or assemblies or of being cut by sharp tools or burned by hot elements.

### **ALWAYS BE CONSCIOUS OF THESE DANGERS!**

## Safety Equipment on the Machines



All machines are delivered with safety equipment, which shall not be removed or bypassed during operation.

The correct functioning of safety equipment on machines and systems should be checked every day and before every new shift starts, after maintenance and repair work, when starting up for the first time and when restarting (e.g. after prolonged shutdowns).

If safety equipment has to be dismantled for setting-up, maintenance or repair work, such safety equipment shall be replaced and checked immediately upon completing the maintenance or repair work. All protective mechanisms shall be fitted and fully operational whenever the machine is at a standstill or if it has been shut down for a longer period of time.

## Damage

If any changes capable of impairing safety are observed in the machine or its mode of operation, such as malfunctions, faults or changes in the machine or tools, appropriate steps must be taken immediately, the machine switched off and a proper lockout tagout procedure followed. The machine should be examined for obvious damage and defects at least once per shift. Damage found shall be immediately remedied by a duly authorized person before resuming operation of machine.

The machine should only be operated when in perfect working order and when all protective mechanisms and safety equipment, such as detachable protective mechanisms, emergency STOP systems, etc. are in place and operational.

## Faults or Errors

The machine must be switched off and all moving or rotating parts allowed to come to a standstill and secured against accidental restart before starting to remedy any faults or errors.

## Signs on the Machine

Safety and danger signs on the machine should be observed and checked at regular intervals to ensure that they are complete and undamaged. They should be clearly visible and legible at all times.

### Clothing, Jewelry, Protective Equipment

Long loose hair, loose-fitting clothes, gloves and jewelry, including rings, should be avoided in order to avoid injuries due to being caught, drawn in and wound up inside the machine.



## Protective Eyewear

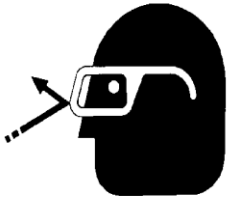

Protective eyewear that has been tested by the local authorities should be worn whenever there is a possibility of loose or flying objects or particles such as when cleaning the machine with compressed air.

## Tools

Always count the number of tools in your possession before starting work on the machine. This will allow you to check that no tools have been left behind inside the machine. Never leave a tool in the machine while working.

## Oils, Lubricants, Chemicals

Note the applicable safety regulations for the product used.

## No Smoking, Fire, Explosion Hazard

Smoking and open flame (e.g. welding work) should be prohibited in the production area due to the risk of fire and explosions.

## Workplace

A clear working area without any obstructions whatsoever is essential for safe operation of the machine. The floor should be level and clean, without any waste.

The workplace should be well lit, either by the general lighting or by local lights.

## Emergency STOP

The emergency STOP buttons bring all machine movements to a standstill. Make sure you know exactly where they are located and how they work. Try them out. Always ensure easy access to the nearest emergency STOP button while working on the machine.

## First Aid

1. Keep calm even when injured.
2. Clear the operator from the danger zone. The decision of what to do and whether to seek additional assistance rests entirely with you, particularly if someone has been trapped.
3. Give First Aid. Special courses are offered by such organizations as the employers' liability insurance association. Your colleagues should be able to rely on you and vice versa.
4. Call an ambulance. Do you know the telephone numbers for the ambulance service, police and fire service?

## Important Notices

### Reporting and Fighting Fires

Read the instructions posted in the factory with regard to reporting fires and the emergency exits. Make sure you know exactly where the fire extinguishers and sprinkler systems are located and how they are operated. Pass on the corresponding information to the firemen when they arrive. Ensure there are enough signs to avoid fire hazards.

The following fire extinguishers may be used:

- Dry powder extinguishers, ABC fire-extinguishing powder.
- Carbon dioxide fire extinguishers to DIN 14461 for electronic components. Great care must be exercised when using carbon dioxide fire extinguishers in confined, badly ventilated rooms (see DIN 14406 and 14270).

Isolate the machine from the power supply if a fire breaks out. Do not use water on burning electrical parts until it is absolutely certain that they have been completely disconnected from the power supply. Burning oils, lubricants, plastics and coatings on the machine can give off gases and vapors that may be harmful to your health.

A qualified person should be consulted to repair the damage after a fire.

### Electrical Power Supply



Before undertaking any maintenance or repair work on the machine, switch off the electrical power to the machine at the main source and secure it with a padlock so that it cannot be switched on again without authorization.

In practice, this may mean that the technician, electrician and operator all attach their own padlock to the master switch simultaneously so that they can carry out their work safely. Locking extension plates should be available for multiple locks if required. The primary purpose for a lockout/tagout procedure is to protect workers from injury caused by unexpected energizing or start-up of equipment.

Energy sources (electrical/pneumatic/hydraulic, etc.) for the equipment shall be turned off or disconnected and the switches locked or labeled with a warning tag. It is the responsibility of the employer to establish control procedures. Follow lockout/tagout procedures before, setup and/or any service or maintenance work is performed, including lubrication, cleaning or clearance of jams.

**Caution: The machine is still not completely de-energized even when the master switch is off.**

- Electricity - The machine is always isolated from the electrical power supply whenever the master switch has been switched off. However, this does not apply for the power supply in the control cabinet, nor for equipment that does not draw its power via the master switch.
- Pneumatic / hydraulic energy - Almost all our machines carry compressed air. In addition to switching off the master switch, the air supply must also be disconnected and the machine checked to ensure it is depressurized before starting any work on the machine; otherwise the machine may execute uncontrolled movements.

- Kinetic energy - Note that some motors or spindles, for example, may continue to run or coast run on after being switched off.
- Potential energy - Individual assemblies may need to be secured if necessary for repair work.

## Delivery of the Machine/Packaging

Note any markings on the packaging, such as weights, lifting points and special information. Avoid temperature fluctuations. Condensation may damage the machine.

## Transport Damage

The packaging and machine must immediately be examined for signs of damage in transit. Such damage must be reported to the shipper/transporter within the applicable time limits. Contact Atlanta Attachment Company and/or your transport insurer immediately, if signs of damage are visible. Never operate a damaged machine.

## Interim Storage

If the machine has to be stored temporarily, it must be oiled or greased and stored in a dry place where it is protected from the weather in order to avoid damage. A corrosion-inhibiting coating should be applied if the machine has to be stored for a longer period of time and additional precautions taken to avoid corrosion.

## Transporting the Machine

Disconnect the machine from all external connections and secure any loose assemblies or parts. Never step under a suspended load. When transporting the machine or assemblies in a crate, ensure that the ropes or arms of a forklift truck are positioned as close to the edge of the crate as possible. The center of gravity is not necessarily in the middle of the crate. Note the accident prevention regulations, safety instructions and local regulations governing transport of the machine and its assemblies.

Only use suitable transport vehicles, hoisting gear and load suspension devices that are in perfect working order and of adequate carrying capacity. Transport should only be entrusted to duly qualified personnel.

Never allow the straps to rest against the machine enclosure and never push or pull sensitive parts of the machine. Ensure that the load is always properly secured. Before or immediately after loading the machine, secure it properly and affix corresponding warnings.

All transport guards and lifting devices must be removed before the machine is started up again. Any parts that are to be removed for transport must be carefully refitted and secured before the machine is started up again.

## Workplace Environment

Our machines are designed for use in enclosed rooms: Permissible ambient temperature approx. 5 - 40 °C (40 - 104 °F). Malfunctions of the control systems and uncontrolled machine movements may occur at temperatures outside this range.

Protect against climatic influences, such as electrostatic charges, lightning strikes, hail, storm damage, high humidity, salinity of the air in coastal regions.

Protect against influences from the surroundings: no structure-borne vibrations, no grinding dust, or chemical vapors.

Protect against unauthorized access.

Ensure that the machine and accessories are set up in a stable position.

Ensure easy access for operation and maintenance (Instruction Manual and layout diagram); also verify that the floor is strong enough to carry the weight of the machine.

## Local Regulations

Particular attention must be paid to local and statutory regulations, etc. when installing machines and the plant (e.g. with regard to the specified escape routes). Note the safety zones in relation to adjacent machines.

## Maintenance

### General Safety Instructions

The machine shall be switched off, come to a standstill and be secured so that it cannot be switched on again inadvertently before starting any maintenance work whatsoever. Use proper lockout/tagout procedures to secure the machine against inadvertent startup.

Remove any oil, grease, dirt and waste from the machine, particularly from the connections and screws, when starting the maintenance and/or repair work. Do not use any corrosive-cleaning agents. Use lint-free rags.

Retighten all screw connections that have to be loosened for the maintenance and repair work. Any safety mechanisms that have to be dismantled for setting-up, maintenance or repair purposes must be refitted and checked immediately after completing the work.

### Maintenance, Care, Adjustment

The activities and intervals specified in the Instruction Manual for carrying out adjustments, maintenance and inspections must be observed and parts replaced as specified.

All hydraulic and pneumatic lines should be examined for leaks, loose connections, rubbing and damage whenever the machine is serviced. Any defects found must be remedied immediately.

### Waste, Disassembly, Disposal

Waste products should be cleared from the machine as soon as possible as not to create a fire hazard. Ensure that fuels and operating lubricants, as well as replacement parts are disposed of in a safe and ecologically acceptable manner. Note the local regulations on pollution control.

When scrapping (disassembling) the machine and its assemblies, ensure that these materials are disposed of safely. Either commission a specialist company familiar with the local regulations or note the local regulations when disposing of these materials yourself. Materials should be sorted properly.

## Repair

### Replacement Parts

We cannot accept any liability whatsoever for damage due to the use of parts made by other manufacturers or due to unqualified repair or modification of the machine.

### Repair, Electrical

The power supply must be switched off (master switch off) and secured so that it cannot be switched on again inadvertently before starting any work on live parts.

Those parts of the machine and plant on which inspection, maintenance or repair work is to be carried out must be isolated from the power supply, if specified. The isolated parts must first be checked to determine that they are truly de-energized before being grounded and short-circuited. Adjacent live parts must also be isolated.

The protective measures implemented (e.g. grounding resistance) must be tested before restarting the machine after all assembly or repair work on electric parts.

Signal generators (limit switches) and other electrical parts on the safety mechanisms must not be removed or bypassed. Only use original fuses or circuit overloads with the specified current rating. The machine must be switched off immediately if a fault develops in the electrical power supply.

The electrical equipment of our machines must be checked at regular intervals and any defects found must be remedied immediately.

If it is necessary to carry out work on live parts, a second person should be on hand to operate the emergency OFF switch or master switch with voltage release in the event of an emergency. The working area should be cordoned off and marked by a warning sign. Only use electrically insulated tools.

### Ventilation/Hazardous Gases

It is the end users responsibility to ensure adequate ventilation is provided to exhaust any and all noxious or hazardous gases that may be present in the working environment.

### Hydraulic and Pneumatic Systems

Work on hydraulic or pneumatic equipment shall only be carried out by persons with training, knowledge and experience of hydraulic systems. Pressure lines shall be depressurized before starting any repair work.

## General Liability

Liability for machine damage and personal injury is extinguished completely if any unauthorized conversions or modifications are undertaken. The machine must not be modified, enlarged or converted in any way capable of affecting safety without the manufacturer's prior approval.

## Starting Machine Movements

Read the Instruction Manual carefully to establish which keys and functions start machine movements.

## A Word to the End User

The end user has sole responsibility to enforce the use of safety procedures and guards on the machine. Any other safety devices or procedures due to local regulations should be should be retrofitted in accordance to these regulations and/or the EC Directive on the safety of machines.

Operator's position must always be readily accessible. Escape routes must always be kept clear and safety areas should be identified.

## Safety Precautions

Safety should be a constant concern for everyone. Always be careful when working with this equipment. While normal safety precautions were taken in the design and manufacture of this equipment, there are some potential safety hazards.

**Everyone involved with the operation and maintenance of this equipment should read and follow the instructions in this manual.**

**Operate the equipment only as stated in this manual. Incorrect use could cause damage to the equipment or personal injury.**

**It is the owner's responsibility to make certain that the operator reads and understands this manual before operating this equipment. It is also the owner's responsibility to make certain that the operator is a qualified and physically able individual, properly trained in the operation of this equipment.**

Specific safety warning decals are located on the equipment near the immediate areas of potential hazards. These decals should not be removed or obliterated. Replace them if they become non-readable.

- ALWAYS keep safety shields and covers in place, except for servicing.
- ALWAYS maintain a safe distance from people when operating.
- ALWAYS operate equipment in daylight or with adequate working lights.
- Follow daily and weekly checklists, making sure hoses are tightly secured and bolts are tightened.
- ALWAYS watch and avoid holes or deep depressions.
- ALWAYS wear adequate eye protection when servicing the hydraulic system and battery.
- NEVER operate a poorly maintained machine.
- NEVER allow persons to operate this machine without proper instruction.
- NEVER put hands or feet under any part of the machine while it is running.
- NEVER leave machine unattended while machine is running.
- NEVER attempt to make any adjustments or repairs to the machine unless you have been properly trained.
- NEVER work under the machine unless it is safely supported with stands, blocks or a hoist and blocks.
- NEVER touch hot parts of machine.

## General Machine Data

Electrical: 220 VAC, 10 A, 50/60 Hz 3 Phase  
 Pneumatic: 70 - 80 PSI, 7 SCFM avg.  
 Sewing Head: Singer Model 300UX5  
 Thread type: D-69B 2 ply bonded nylon or similar  
 Sewing Speed: 3500 RPM  
 Stitch Density: 7-8 SPI

## Physical Dimensions

Machine Height: 6 ft.

Floor Area: 175 ft.<sup>2</sup>

Weight: Approx. 1300 lbs.

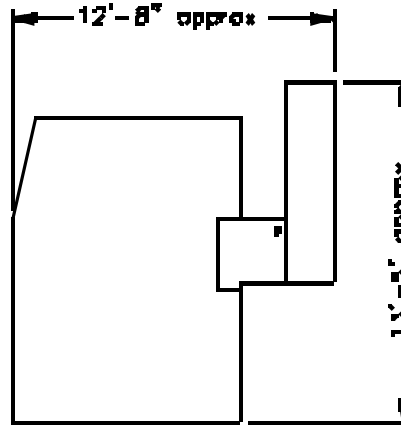

## Touch-Screen Operation

The graphics images presented on the touch screen show "3-dimensional" buttons, which may be pressed to access other screens, change counters and timers, or actuate hardware. Areas lacking the "3- dimensional" border contain information only. Counters are identified with the "+" and "-"

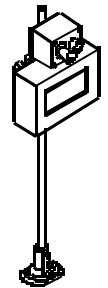

" buttons in the corners. These counters may be adjusted by pressing the "+" and "-" boxes. Pressing the dark area of the counter button will access another screen that gives detailed information about the counter and how to adjust it. Pressing RESET from any screen clears all machine functions and returns to the 1335 READY page. Normal operation of the machine is controlled from the 1335 READY page. From here you can START the auto cycle, access the SETUP, MANUAL, PIECE COUNT, and STYLE pages. You can also activate the THREAD PULL-OFF and the ACCUMULATOR. The

1335 READY page allows anyone to access the necessary functions and adjustments needed for normal operation of the machine.

There are also advanced functions that are only accessible by an authorized mechanic and include: timers and counters that control machine hardware, input and output test screens, and machine statistics. To get to the advanced functions the appropriate password must be entered at the security screen. Security access is reset whenever the main power is turned off, or the RESET button on the 1335 READY page is pressed.



## Light Tower Functions

The purpose of the Light Tower is to provide a visual indication of the current status of the machine that can be seen at a considerable distance from the machine. Definitions for the different light states currently available on the 1335 are included below.

Light Status	Definition
Green Steady	Machine is making a panel.
Green Flashing	Machine is sewing the last side of the panel and will finish soon.
Yellow Steady	Machine is on but idling between panels.
Yellow Flashing	Machine is stopped in the middle of a panel and needs operator attention before continuing. Possibly the machine has stopped because of an error, thread break, etc. If the operator cannot recover, the mechanic must be called.
Red	Available for future use, not currently utilized

## Basic Machine Operation

### Loading the Gusset Roll and Accumulator

1. Load the roll of gusset material onto the roll holder between the two discs so that when the material is fed toward the accumulator the good side of the fabric is up.
2. Be sure the drag tension tape is draped over the top of the roll and the discs are snug against the roll core.
3. Feed the gusset straight between the movable and stationary rollers toward the right angle guide.
4. Feed it around the right angle guide and over to the upper folder guide.

### Loading and Adjusting the Folders

1. Feed the gusset under the right upper guide rod and over the left upper guide rod and down toward the folder.
2. Open the ends of both folders for easier loading.
3. Feed the gusset material through the first folder, around the tension plate, and through the second folder. Be sure the folder tongues are inside the folded gusset.
4. Close the folders.
5. Loosen the folder lock screws and slide the folders left or right as needed to make a close fit on the folded gusset.
6. Tighten the lock screws.
7. Pull the gusset material through the second folder toward the sewing head until the end of it is about 2" beyond the end of the stripper blade. It is necessary to have about 1-1/2" of unsewn gusset at the start of the panel for the finishing overlap.
8. Lower the folder assembly and push it all the way in toward the machine so that the gusset is under the presser foot and the folder in as far as it will go. The machine will not start the automatic cycle if the folder assembly is not in all the way.
9. If the presser foot is not up, press the LOAD PANEL button or RESET.

## Adjusting the Active Edge Guiding

The active edge guide located under the cloth plate controls the position of the panel while sewing. The position of the panel left to right is determined by the electric eye that looks up through a hole in the cloth plate at the reflective tape on the bottom of the folder. This eye is positioned by turning the small plastic knob to the right of the eye. Turning the knob clockwise moves the eye and the panel position to the right. Adjust as necessary to align the edge of the panel to the edge of the gusset. Set the alignment guide to match the position of the edge guide to aid in loading the panel

## Starting the Automatic Cycle

With the gusset loaded and the folder all the way in, position the panel under the presser foot in the middle of a short side and aligned with the alignment guide. If this panel is the last one to be sewn with the current gusset roll, start the automatic cycle with the START SINGLE button. If the next panel will use the same gusset roll, start the cycle with the START MULTIPLE button. When you start with the START MULTIPLE button the Accumulator will activate at the end of the cycle (while you are unloading the finished panel and getting the next panel) so by the time you are ready to start the next panel the Accumulator will be finished and the machine will be ready to run.

After pressing the START button, the automatic cycle will begin. The presser foot will drop and sewing will begin. At the same time the trap door will rise and fill in the opening in front of the sewing head. The operator must step aside to allow the trap door to move. Keep hands, etc., clear of the trap door while it is moving. The machine will sew all four sides of the panel, ruffling the corners, stop at over-sew, cut the gusset, and position the folder out of the way for closing the gusset and finishing the panel.

## Making Adjustments to Settings

Before starting a panel, be sure the correct STYLE has been selected. The STYLE sets up all the counters and timers and other settings that control the sewing operation. Its main function is to set-up the air jets for turning the different size panels and to set the correct gusset tension and blower setting for the type of panel being sewn; either MNQ (quilted) or PLAIN. To change the STYLE press the STYLE button and the SELECT STYLE MENU 1 page will appear. Pressing the arrow button at the top of the page will display the SELECT STYLE MENU 2 page for more style settings. Select the desired style and the STYLE page will appear. Press the RECALL SETTINGS button. The display will return to the 1335 READY page.

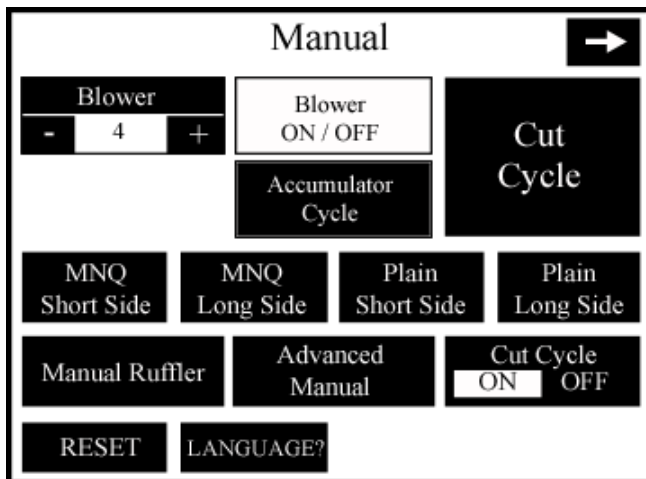
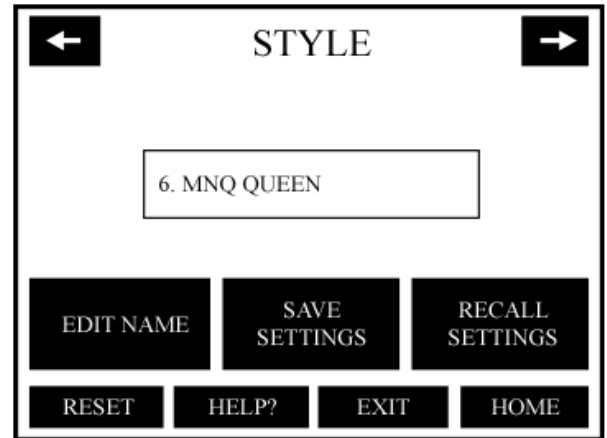

Pressing the MANUAL button displays the MANUAL page. Here you can temporarily change the blower speed setting, turn the blower on and off, cycle the knife, turn on the Ruffler, disable the knife, and turn on the individual tension regulators to make adjustments to the gusset tension settings.

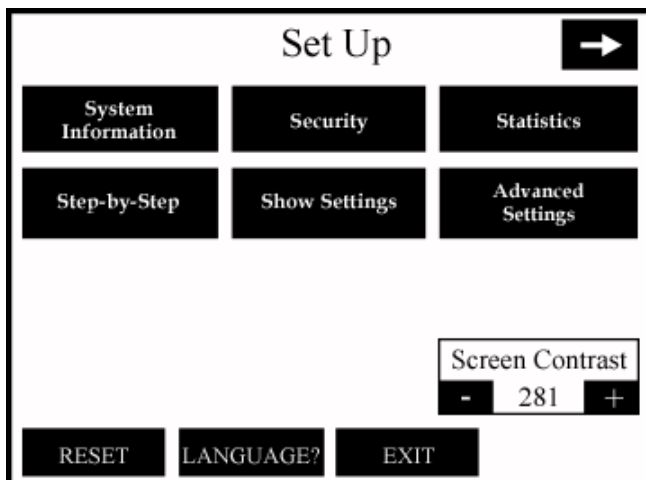

Pressing the SETUP button displays the SETUP page. From here you can access System Information, change Security codes, display Statistics, show all Settings on one screen, adjust screen Contrast, run the machine in Step-by-Step mode, and temporarily change the air jets for the first and second sides of the panel.

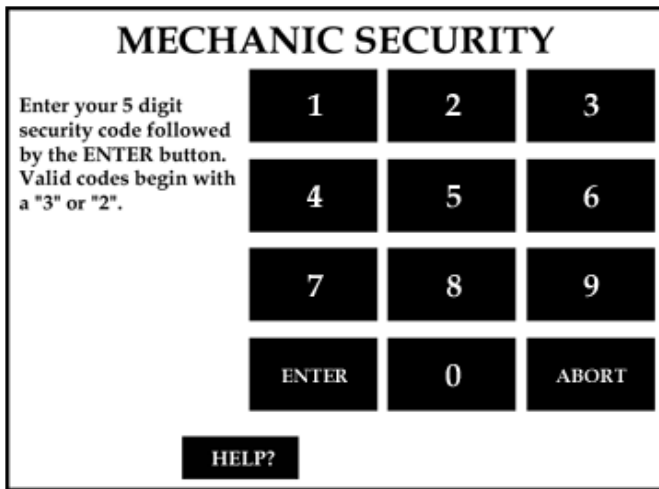

Pressing the ADVANCDE SETUP button or the arrow button at the top of the SETUP page displays the Security page for inputting the mechanic's access code. Once this code has been entered you can access the ADVANCED SETUP pages and adjust other machine settings. The access code remains active until the RESET button from the READY page is pressed or power is disconnected. Changing the access code to "00000" will disable the security function and allow full access to all settings.

## Finishing the Panel

When the machine has finished the panel the operator must fold the trailing edge of the gusset back about 3/4" and tuck it into the starting edge fold. Step on the right SEW pedal to run the machine at a medium speed until the desired over-sew is achieved. Tap the left FOOT LIFT pedal and the thread pull-offs will activate and the presser foot will lift. **Note: The FOOT LIFT pedal will not function until the SEW pedal has been used.** Remove the panel to the left and trim the threads on the cutter provided. If the machine had been started in the START MULTIPLE mode, the Accumulator will cycle and the machine will be ready for the next panel.

## Adjusting the Corner Ruffles

### Ruffles vs. Stitches

When the machine turns a corner the number of stitches that will be sewn in the corner is controlled solely by the speed of the turning clamps because turning stops as soon as the OUT limit switch is reached. The speed of the turning clamps is set with the Thumbwheels on the middle stepper control box. This speed should be adjusted so that the number of stitches in the corner is equal to or greater than the number of Ruffles that will be set in the corner. (The number of Ruffles is set with counter #5) The chart below shows the correct setting of the stepper box for the desired number of stitches in the corner. You can sew more stitches than Ruffles but not more Ruffles than stitches because ruffling also stops when the OUT limit switch is reached.

<u>Stepper Thumbwheel Setting</u>	<u>Number of Stitches in Corner</u>
900	5
800	6
700	7
600	8
500	9

### Ruffle Size

The Ruffle size is determined by the stroke of the Ruffler blade from its OUT position to it's IN position. The IN position is set to control where the needle pierces the Ruffle and is adjusted to pierce in the middle of the fold. The width of the Ruffle is controlled by the OUT position and is adjusted with the round knob near the handwheel. Adjust the Ruffle size so that the outer edge of the corner radius lays flat.

## Settings Menus

The settings menus are comprised of the three ADVANCED SETUP pages. They are accessed through the SETUP button and the ADVANCED SETUP button or the arrow button on the SETUP page. A mechanics security code must be entered in the security page for these settings to be available. The following is a list of all settings and their functions.

**1. Blower:** Controls the speed of the air table Blower motor. A setting of 0 is off, 1 is the lowest speed, and 7 is the highest speed. This does the same thing as the blower control buttons on the MANUAL page.

**2. Not used.**

**3. Knife On Time:** The on time of the Knife chop solenoid in 1/100ths seconds. Adjust so that the knife blade makes a full stroke and a complete cut of the gusset.

**4. Thd Pull Off Time:** The on time of the Thread Pull-off solenoid is 1/100 ths seconds. Adjust so that the Thread Pull-off cylinders make a full stroke.

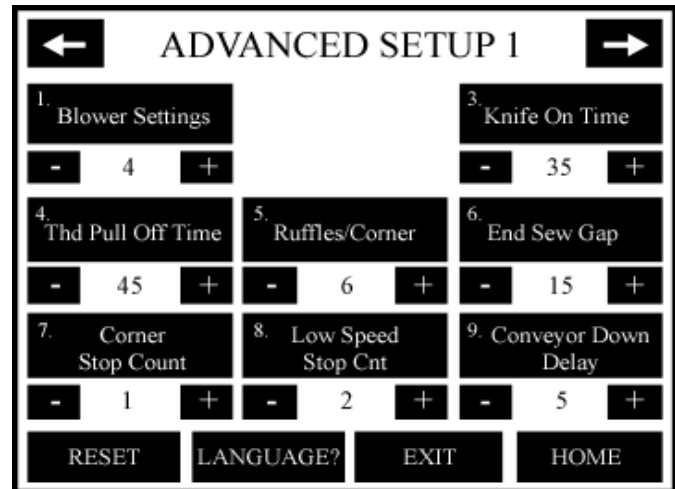

**5. Ruffles / Corner:** This is the number of Ruffles that will be made in each corner. When the Rotator reaches the Out Limit Switch any remaining ruffles will be ignored. Adjust the number of ruffles along with the speed of the turning so that all required ruffles are completed in the turn.

**6. End Sew Gap:** The number of stitches used by the control to stop the sewing if the gusset End Detector Sensor misses the end of the gusset on the last side of the panel. Acts as a safety device to keep the machine from "running away". If this counter is set to "0" the safety feature is disabled.

**7. Corner Stop Cnt:** A stitch count used to adjust the stopping position of the panel at the corners. Adjust so that the panel stops approximately 3" from the needle. When this counter is set correctly, the edge of the panel will line up with the right edge guide plate at the end of the corner ruffle. This is the primary counter used to set the corner stopping position.

**8. Low Speed Stop Cnt:** This is a stitch count at positioning speed to control the stopping of the sewing head. It is adjusted so that there is one slow stitch as the machine stops sewing in the corners. This count is proportional to sewing speed.

**9. Conveyor Down Delay:** The time from the Sew Jam Eye seeing the leading edge of the panel until the Conveyor drops. Adjust so that the ruffled corner is completely under the conveyor before it drops. This time is in 1/100ths seconds.

**10. Edge Guide Jam Delay:** The amount of time the Edge Guide Eye can remain in one state (light or dark) before a jam error will occur. This time is in 1/100ths seconds.

**11. Looper Thd Det. Delay:** The time from the sewing head starting in high speed until the Looper thread detector becomes active. Adjust to allow the head to reach full speed before the thread detector becomes active. This time is in 1/100ths seconds. If this time is too short, false thread breaks will occur at start-up.

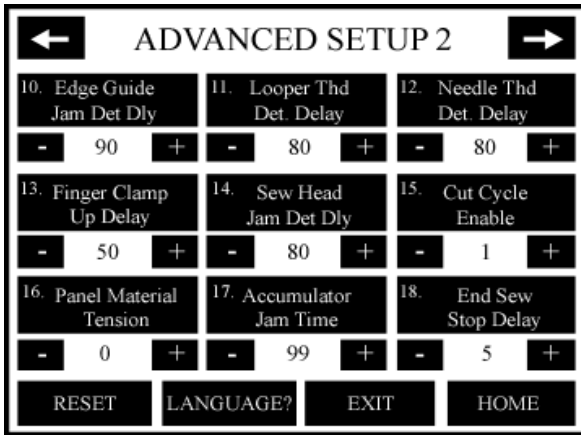

**12. Needle Thd Det Delay:** The time from the sewing head starting in high speed until the needle thread detector becomes active. Adjust to allow the head to reach full speed before the thread detector becomes active. This time is in 1/100ths seconds. If this time is too short, false thread breaks will occur at start-up.

**13. Finger Clamp Up Delay:** The time from the Finger Clamp solenoid turning off until the Clamps Up solenoid turns off. This allows time for the Finger Clamp to get out from under the folder before it and the clamps rise. This time is in 1/100ths seconds.

**14. Sew Head Jam Det Dly:** The time from the start of sewing until the Sew Jam Det. Eye should be covered. If the eye is not covered in this time a jam error will occur. This time is in 1/10ths seconds.

**15. Cut Cycle Enable:** Set this counter to "0" to turn off the gusset knife. This setting is mainly used for testing purposes. Normally set to "1". This does the same thing as the Cut Cycle On/Off button on the MANUAL page.

**16. Panel Material Tension:** This counter is used to select the gusset tension regulators for MNQ panels (0) or PLAIN panels (1).

**17. Accumulator Jam Time:** The time allowed for the accumulator rollers to move to the bottom of their stroke. If the rollers do not reach the down sensor in this amount of time an error will occur. This time is in 1/10ths seconds.

**18. End Sew Stop Delay:** The number of stitches sewn after the gusset End Detector sees the starting end of the gusset and sewing stops. Use this counter to adjust the amount of overlap of the gusset material needed for closing. Setting this counter to "0" disables the End Detector and causes the machine to stop based on the End Sew Gap setting.

**19. Soffie Jets First Side:** Controls whether the Soffie Jets are blowing on the first side of the panel. "1" = on, "0" = off. This setting is usually set to "0" for Twin and Full panels and "1" for Queen and King.

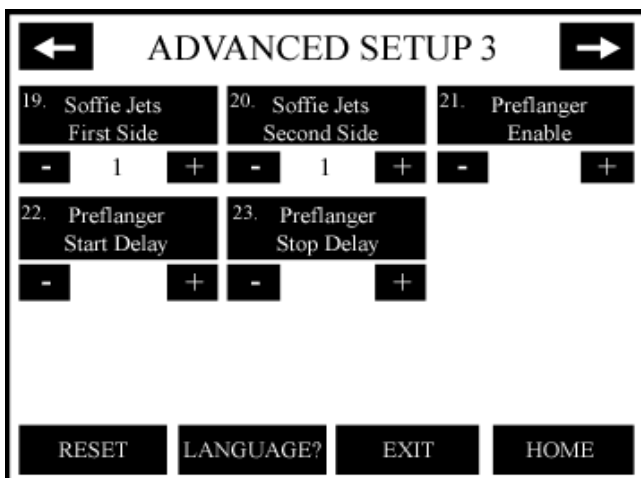

**20. Soffie Jets Second Side:** Controls whether the Soffie Jets are blowing on the second side of the panel. "1" = on, "0" = off. This setting is usually set to "0" for Twin and Full panels and "1" for Queen and King.

**24-27. Not used.**

## Styles

All of the current settings of the machine can be saved as a STYLE and recalled later to reuse. Also, an existing STYLE can be recalled, edited, and copied.

### Creating A New Style

In the 1335 READY page press the STYLE button.

In the SELECT STYLE MENU 1 or 2 page select an unused style to edit.

In the STYLE page press EDIT NAME.

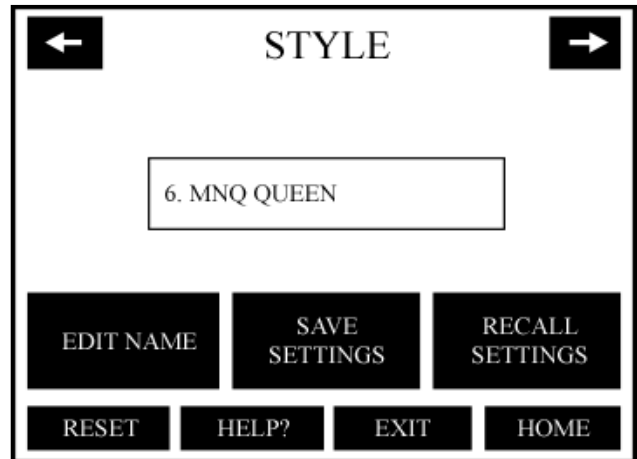

In the STYLE NAME EDIT menu use the Cursor Left and Cursor Right buttons to position the cursor over the first character to change. Use the Letter Forward and Letter Back buttons to change the character as desired. Continue to move the cursor and enter or change characters until the desired "Name" is entered. Available characters include A-Z, 0-9, /,.,-, and Blank. Use the "Blank" character to erase unwanted characters. Press EXIT.



In the STYLE menu press SAVE SETTINGS.

Press EXIT.

### Recalling A Style

**Note:** When recalling a STYLE, all the current settings will be lost if they have not been saved.

In the 1335 READY page press the STYLE button.

In the SELECT STYLE MENU 1 or 2 page select the desired style to recall.

In the STYLE page press RECALL SETTINGS. If the WARNING page displays, press RECALL SETTINGS again and then press EXIT.

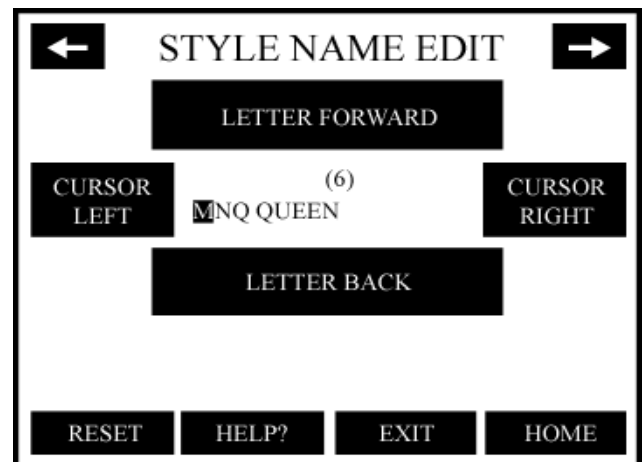



## Editing an Existing Style

In the 1335 READY page press the STYLE button.

In the SELECT STYLE MENU 1 or 2 page select the desired style to recall.

In the STYLE page press RECALL SETTINGS.

If the WARNING page displays, press RECALL SETTINGS again and then press EXIT

Edit the machine settings as desired.

In the 1335 READY page press the STYLE button.

In the SELECT STYLE MENU 1 or 2 page select the same style you are already in.

In the STYLE page press SAVE SETTINGS.

Press EXIT.

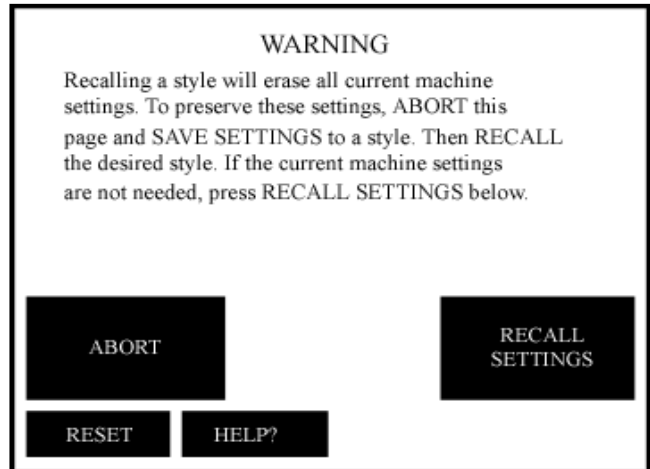

## Copying an Existing Style

In the 1335 READY page press the STYLE button.

In the SELECT STYLE MENU 1 or 2 page select the desired style to copy.

In the STYLE page press RECALL SETTINGS.

If the WARNING page displays, press RECALL SETTINGS again and then press EXIT

In the 1335 READY page press the STYLE button.

In the SELECT STYLE MENU 1 or 2 page select the style you want to copy to.

In the STYLE page press SAVE SETTINGS.

Press EXIT.



## General Machine Adjustments

Set all air supply pressure regulators:

Main	80 PSI
Sewing Blowers	40 PSI
Turning Blowers	40 PSI
Turning Clamps	10 PSI
Edge Guide	30 PSI

Set all gusset tension pressure regulators:

(The regulators can be turned on from the MANUAL page.)

MNQ Short Side	5 PSI
MNQ Long Side	7 PSI
Plain Short Side	2 PSI
Plain Long Side	3 PSI

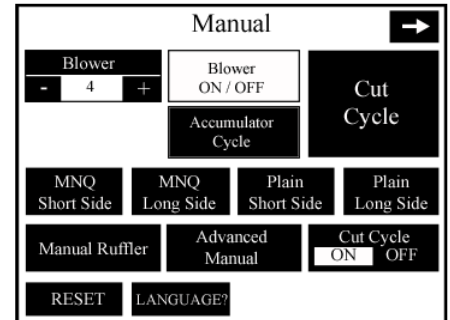

Set the Low Air Pressure switch to trip at 60 PSI.

Set the stepper control box's thumbwheels and jog speeds:

Set the top box (Puller) to "420" on the thumbwheels.

Set the middle box (Rotator) to "850" on the thumbwheels.

Set the middle box (Rotator) jog knob to "54" on the dial.

Set the bottom box (Conveyor) to "420" on the thumbwheels.

Set the bottom box (Edge Guide) jog pot for 80 RPM at the edge guide wheel.

(Remove cover for access.)

Refer to the speed control manual for programming instructions.

Set the Soffie jets in the air table so that they blow in the directions noted on the 1335Q-PD2 Pneumatic Diagram. Set the flow controls on the jets to be all the way open.

Set all flow controls for smooth, quiet motions of all cylinders. Set all cylinder limit switches at the ends of strokes.

### Electric Eye Sensor Adjustment

To adjust the sensor, first remove the clear plastic cover from the end of the sensor. There are two adjusting screws under the cover. One is labeled "GAIN" and is used to set the sensitivity of the sensor. The other screw is labeled "DO & LO" and should always be fully clockwise.

With the end of the sensor pointing at the center of the reflective tape, turn the "GAIN" screw counter-clockwise until the red LED indicator is off. Then turn the "GAIN" screw clockwise until the LED indicator comes on. Then turn the "GAIN" screw one full turn clockwise. The LED indicator should be blinking slowly.

Cover the eye so that the sensor cannot see the reflective tape and the LED should go off.

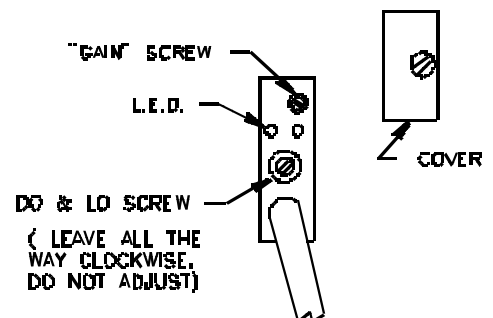

### Reflective Tape Maintenance

Use a soft cloth for cleaning.

Do not use chemicals or abrasives to clean it.

Avoid any contact with oils and liquids.

Do not touch the tape with bare fingers.

If tape is dirty or opaque, the eye may not function correctly.

## Sewing Head and Motor

Program the Panasonic sewing motor parameters as follows:

Mode	106 - Y2
Positioning Speed	132 - 100 RPM
High Speed	135 - 3500 RPM
Foot Lift Modulation	605 - 64
Foot Lift Modulation	606 - 1

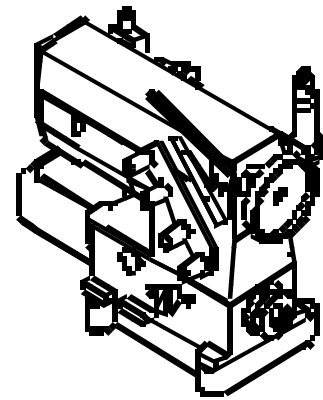

Set the correct rotation direction.

Set the sewing stitch length to 7 SPI.

Set the needle up position to be 20 degrees before top dead center. Do this by rotating the outside 1311-003B Tape Collar at the hand wheel. The needle up position is where the needle will be when the Ruffler blade starts its IN stroke. This is also the sewing motor's needle up position.

Set needle down eye position to be 20 degrees before bottom dead center. Do this by rotating the inside 1311-003B Tape Collar at the hand wheel. The needle down position is where the needle will be when the Ruffler blade starts its OUT stroke. This needle down eye position is not related to the sewing motor's needle down position.

Set the presser foot height. When the presser foot is up, there should be ¼" between the bottom of the foot and the throat plate. Adjust according to Yamato sewing machine manual.

Set the position of the two shock absorbers on the Ruffler Drive Assembly. The rear shock should extend 1" of thread out from the bracket toward the front of the machine. The front shock should extend ½" of thread out from its bracket toward the rear of the machine.

### Ruffler Drive Assembly

Set the Ruffler blade position left to right. The slot in the Ruffler blade should align with the sewing needle. Loosen the clamp screw and adjust the left Ruffler arm.

Set the Ruffler blade IN position so that the Ruffler blade extends 1/8" past the needle when the needle is at bottom dead center. **CAUTION - the Ruffler cylinder is very strong, keep hands, etc., away from the Ruffler blade when it is moving by air power. Make this adjustment with the air turned off.** Loosen the clamp screw on the right drive arm and with the right drive arm pushed all the way in compressing the rear Ruffler shock absorber, rotate the Ruffler blade holder as needed.

Set the Ruffler blade OUT position so that the Ruffler blade is ¾" in front of the needle. Make this adjustment by turning the large plastic adjusting knob in front of the Ruffler drive bracket. (Turn the air back on.)

Set the ruffling foot lift cylinder position so that the foot is lifted 1/8" when the Ruffler blade is in. Adjust by sliding the foot lift arm up or down the cylinder rod. Disconnect and cap off the front air line on the Ruffler cylinder and turn on and off the Ruffler cylinder while making this adjustment.

Set the blade drive arm so that when the Ruffler blade is down and touching the stripper blade there is still 1/8" of cylinder rod showing on the blade lift cylinder.

## Folder Assembly

Adjust the shock absorber, stop screw, and rod end on the folder sub-assembly so that the folder assembly is level with the cloth plate in the down position.

Adjust the up position shock absorber so that the shock bottoms out when the cylinder bottoms out.

Adjust the stripper blade mount so that the tip of the blade is 1/8" above the throat plate at the presser foot and the clearance under the folder at the guide wheel is 1/4".

Adjust the rod end on the in/out cylinder so that the end of the stripper blade is 1/4" in front of the needle at needle bottom dead center. Set the cylinder limit switches for proper operation at the ends of stroke.

Adjust the folder left to right so that the right edge is 2-1/4" to the right of the needle.

Set the folders for a 2-1/2" folded capacity.

Adjust the guide rods to be perpendicular to and centered on the center-line of the top folder.

Adjust the tension cylinder so that the tension plate opens 1/4" when the tension pressure is off. **Note: Lifting the puller forces the tension plate open. Be sure the cylinder does not bottom out when the tension is on.**

Adjust the height of the gusset end detector to be 1/16" above the cloth plate when it is in its down position. Adjust the photocell for proper sensitivity.

## Edge Guide Assembly

Adjust the edge guide so that the wheel is centered on the cutout in the cloth plate and in contact with the bottom of the folder when it is in its up position. Check for proper belt tension when the wheel is up. Be sure the lift cylinder does not bottom out when the wheel is in the up position against the bottom of the folder. Adjust the flow controls for smooth, quiet operation.

Adjust the edge guide eye to be looking up through the cutout in the cloth plate and at the same place left to right as the right edge of the folder. Be sure there is reflective tape on the bottom of the folder for the eye to see. There should be another 1/4" of adjustment left and right in the adjusting screw from this position.

## Rotator Assembly

Adjust the Rotator so that the center of rotation is located  $\frac{3}{4}$ " to the left of the needle and even with the needle at bottom dead center. The Rotator shaft must be perpendicular to the cloth plate. Adjust the pillow block bearings as necessary.

The Rotate Arm should be set for 2-1/2" clearance above the cloth plate.

Set the limit sensors and shock absorbers for 90 degrees of rotation with the Rotate Arm parallel to the edge of the air table in its rear position.

**CAUTION: When rotating the arm by hand, be sure to unplug the stepper motor to prevent damage to the motor drive unit.**

Set the panel clamps to just barely touch the cloth plate when they are in their down position.

The small hole in the tip of the offset finger of the inside clamp foot should align with the center of rotation of the Rotator shaft ( $\frac{3}{4}$ " to the left of the needle). Rotate the arm 90 degrees and check in both positions.

The finger clamp pressure plate should be set flush with the bottom of the other clamps. Set the rotary actuator for 90 degrees of rotation.

The Sew Head Jam Detector Eye should be looking at reflective tape placed right behind the puller and between the conveyor and the edge guide plate.

The Trailing Edge Eye should be looking at a piece of reflective tape located at the left side of the guide wheel cutout hole in the cloth plate and 4-1/2" in front of the needle location.

Adjust the Blower Tube flow control so the panel stays flat on the cloth plate while rotating. Adjust the eye on top of the Ruffler cover to be looking at a 2" square piece of reflective tape located even with the needle and 30" from the edge of the air table nearest the sewing machine.

## Puller Assembly

Set the puller down position as low as practical without actually touching the cloth plate. The rollers should be centered on the needle.

## Knife Assembly

Adjust the front to back position of the pivot arm on the shaft so that the knife swings down to the cloth plate without hitting anything.

The knife should be level at the down position.

The tip of the lower knife blade should clear the stripper blade by 1/16" as it swings down and extend 1/2" to the right of the right edge guide of the folder. (The folder must be all the way out.)

Set the pivot arm limit sensors for top and bottom of stroke.

Adjust the shock absorbers so they do not completely bottom out.

Set the safety eye (Knife Obstacle Sensor) position so it will not activate as the knife swings through its entire stroke.

## Rear Conveyor Assembly

Set the conveyor so it is level, parallel to the edge of the air table, and in line with the right puller roller.

Set the height stop to hold the conveyor 1/32" above the cloth plate.

Set the spring adjustments to make the conveyor press down with about 1-2 lbs. of weight.

Set the lift cylinder to press the conveyor arm down far enough to activate the UP sensor.

## Accumulator Assembly

Set the down sensor to activate at the bottom of the stroke.

Set the set collars on the stationary rollers tight against the rollers to provide a little friction to the rollers to help prevent the accumulated loops from unrolling and falling to the bottom of the accumulator.

Set the Material Out Eye to see reflective tape wrapped around the center of the nearest stationary roller.

## 1334 Auto Flanging Unit

The 1334 Auto Flanging Unit is an optional piece of equipment that attaches to the 1335 unit. The Autoflanger folds and sews the flange and gusset materials together before it is sewn to the pillowtop panel by the 1335 unit.

### Sequence of Operation

Press the Start button on the touch screen.

The Accumulator will accumulate enough material necessary to complete one cycle.

If the Slack Eye is uncovered, material will advance through the sewing head and slack will accumulate in the Slack Trough until the Slack Eye is covered.

Once the Slack Eye is covered, the 1335 will activate and continue until the Slack Eye is uncovered again or a cycle is completed.

Steps 2-4 repeated.

## 11335AS88A Recommended Spare Parts List

Contact AAC’s sales department to order replacement parts.

Phone: 770-963-7369

Fax: 770-963-7641

Email: sales@atlatt.com

Website: www.atlatt.com

### AAC Part # SP1335AS88A Spare Parts Kit

NO.	QTY	PART #	DESCRIPTION	NO.	QTY	PART #	DESCRIPTION
1	1	1278-7055B	Prox Switch	14	1	AT301-08A	Lower Cutter
2	2	1325-3602B	Ruffer Blade	15	1	AT301-09	Upper Cutter
3	2	1325-3773B	Stripper Blade	16	3	EEFE-RR2	Reflective Tape
4	1	23140A	Electric Eye	17	1	FFSM312LVQ	Electric Eye
5	3	39500KM	Cutter	18	1	GG180XL037	Gear Belt
6	1	4003-IS3WT2	Thread Break Sensor	19	1	GG187L050	Gear Belt
7	1	4080-110	Quad Input Module	20	1	GG225L050	Gear Belt
8	1	4080-120	Dual Opto-Iso Module	21	1	GGD540L050	Gear Belt
9	1	4080-130	Quad Opto-Iso Module	22	4	MM9540K22	Rubber Bumper
10	1	4080-140	Quad Output Module	23	2	MMJ510	Eyelet
11	1	AAEDY59A-10	Switch	24	100	SN11316	Needle
12	1	AAEHSKQ	Switch, Hall Effect	25	100	SN62X5924	Needle
13	1	AAPR025IF2B	Shock Absorber				

# Maintenance

## Daily

Clean machine at the end of every shift

Clean lint etc. from the Looper area on the sewing head

Remove any threads wrapped around moving parts of the puller, conveyor, and accumulator rollers.

Wipe all photo eye lenses with clean, nonabrasive, dry cloth

Use blow-off hose to get rid of excess lint, thread and other clippings

Properly maintain the Singer sewing head - follow Singer recommendations and guidelines for daily maintenance and lubricating of the head.

## Weekly

Check all belts for tightness and condition. Adjust or replace as necessary.

Check and clean the screens on the blower box.

Check blower v-belt tension and pulleys.

Put one drop of machine oil on all moving Ruffler parts.

## Monthly

The Gusset Knife movable blade and rod end have been pre-lubricated with Teflon grease and should never be "oiled". Re-lubricate with Teflon grease as needed.

The puller and conveyor needle bearings have been pre-lubricated with Teflon grease and should never be "oiled". Re-lubricate with Teflon grease as needed.

## Cleaning Electric Eyes and Sensors

The following illustrations show the names and locations of the electronic eyes and sensors on the 1335 unit. All of these eyes and sensors should be cleaned regularly or after each shift. The Edge Guide Eye should be cleaned even more often. Check the Edge Guide Eye hourly for lint buildup. Clean if necessary. Clean the eyes with a clean, soft cloth.

**Gussett Material  
Out Eye**



**End Of Sew Eye**

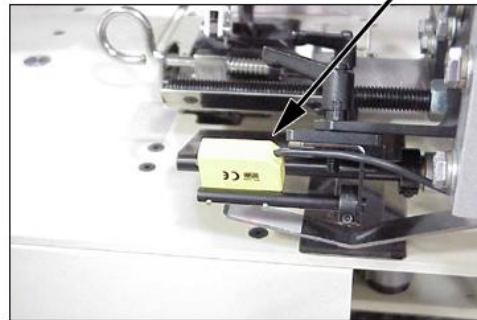

**Flange Material Eye**



**Edge Guide Eye**

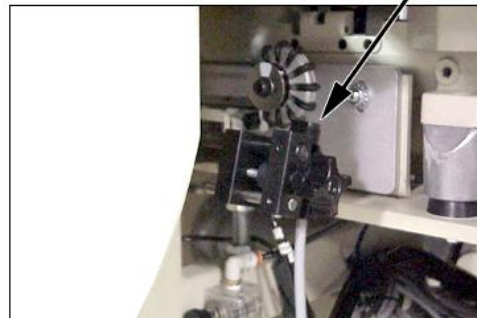



**Trailing Edge Eye**

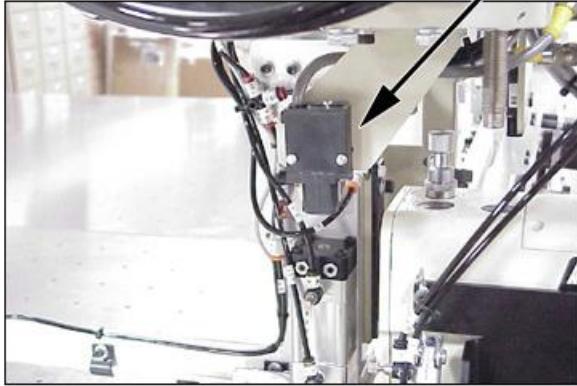

**Soffie Jet Eye**



**Needle Up Eye  
Needle Down Eye**



**Knife Obstacle Sensor**

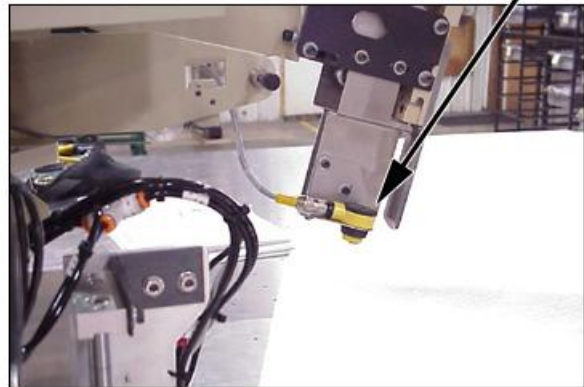

**Preflanger Slack Eye**



**Jam Detect Eye**

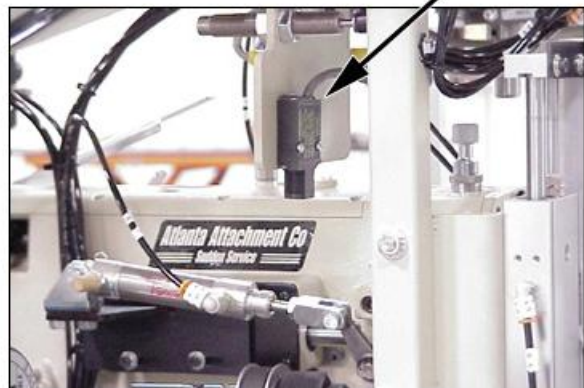



## Assembly Drawings & Parts Lists

The materials contained herein are confidential and proprietary information of Atlanta Attachment Company. In addition to any confidentiality and non-disclosure obligations that currently exist between you and Atlanta Attachment Company, your use of these materials serves as an acknowledgment of the confidential and proprietary nature of these materials and your duty not to make any unauthorized use or disclosure of these materials.



**One-Stop Shopping**  
For Expendable Replacement Parts for AAC & Other Bedding Equipment Suppliers  
Toll Free: **1-866-885-5100**  
[www.atlantapartsdepot.com](http://www.atlantapartsdepot.com) • [sales@atlantapartsdepot.com](mailto:sales@atlantapartsdepot.com)

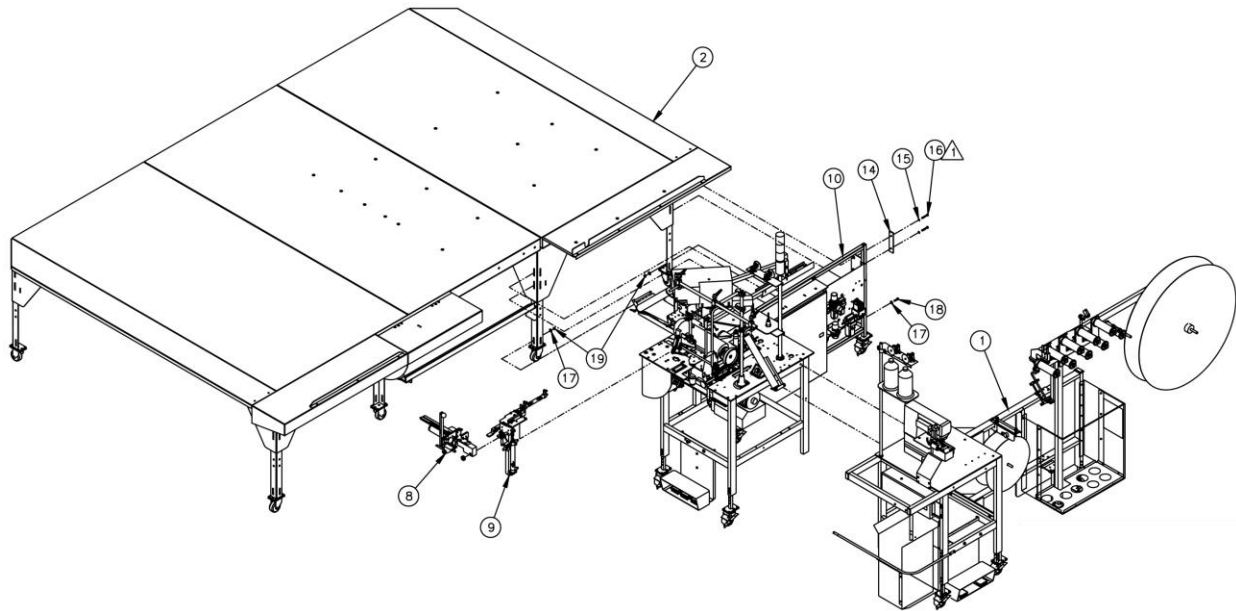

## 1135AS88A Auto Pillowtop Ruffler w/Flange, Flat Style

AAC Drawing Number 192773C Rev3

NO.	QTY	PART #	DESCRIPTION
1	1	11334QY28A	Auto Flanging Module
2	1	1335000	Air Table Assy
3	AR	1334-3000WD1	Wiring Diagram
4	AR	1335Q-PD2	Pneumatic Diagram
5	1	ZZV1335A	Instructional Video
6	AR	1335Q-910AWD3	Wiring Diagram
7	AR	1335-905	Stepper Box Adjustments
8	1	1335A-300	Folder Assy
9	1	1335B-301	Folder Slide/Pivot Assy
10	1	1335A-425	Console Assy
11	1	1335Q-900A	Main Elec. Panel, Mod
12	AR	1335Q-900AWD2	Wiring Diagram
13	AR	ZZ1335AS88A	Technical Manual
14	2	1335093	Washer Plate
15	4	WWL1/4	Lock Washer
16	4	SSHCO1080	Screw, Hex Cap
17	4	WWFS1/4	Flat Washer
18	2	SSHCO1048	Screw, Hex Cap
19	2	NNK1/4-20	Kep Nut

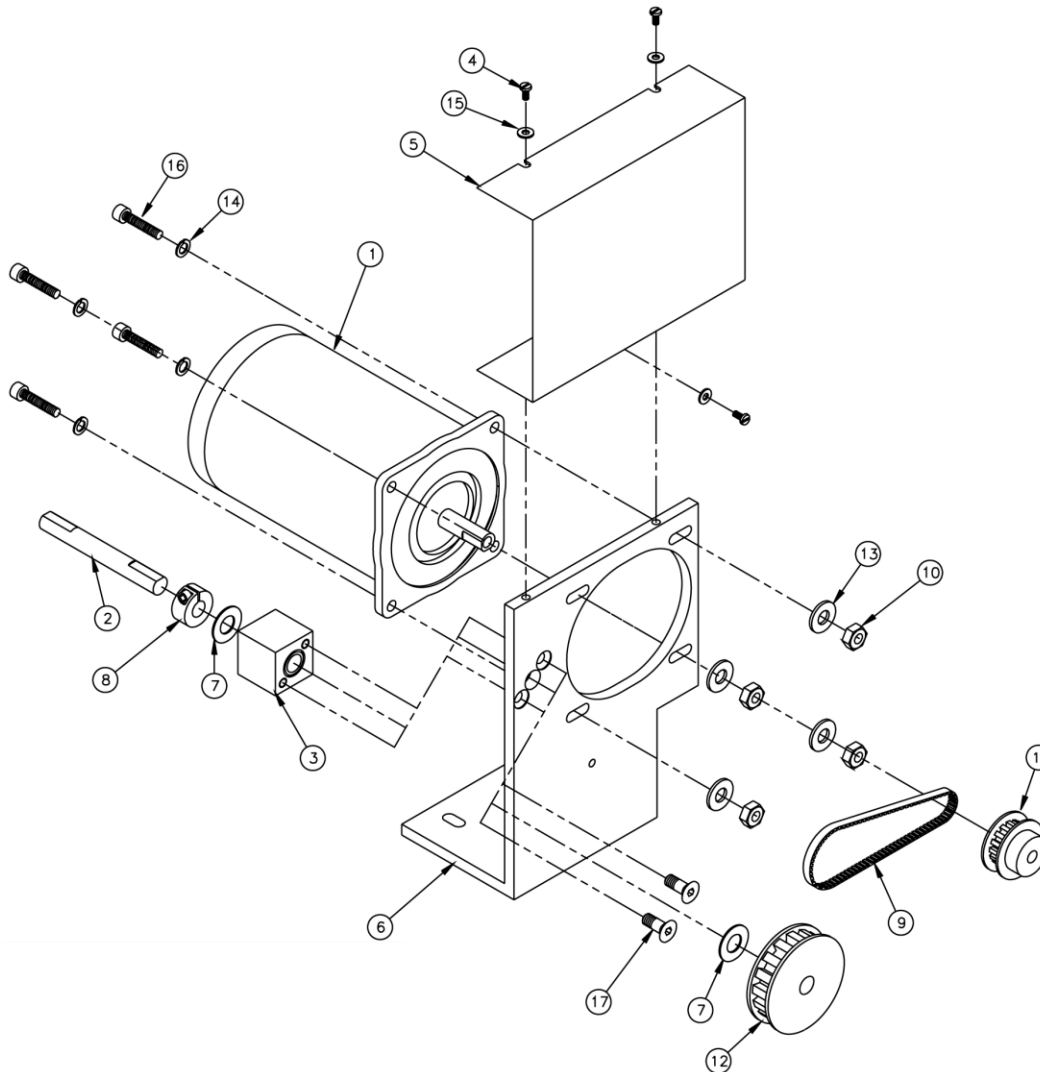

From the library of: Diamond Needle Corp

## 1335-120 Puller Drive Assembly

AAC Drawing Number 192446C Rev2

NO.	QTY	PART #	DESCRIPTION
1	1	011-020	Step Motor
2	1	1335-116	Shaft
3	1	1335-119	Bearing Block
4	3	SSPS80024	Screw, Pan Head
5	1	1335-124	Guard
6	1	1335-125	Motor Mount
7	2	3517	Thrust Washer
8	1	CCCL6F	Clamp Collar
9	1	GG100XL037	Gear Belt

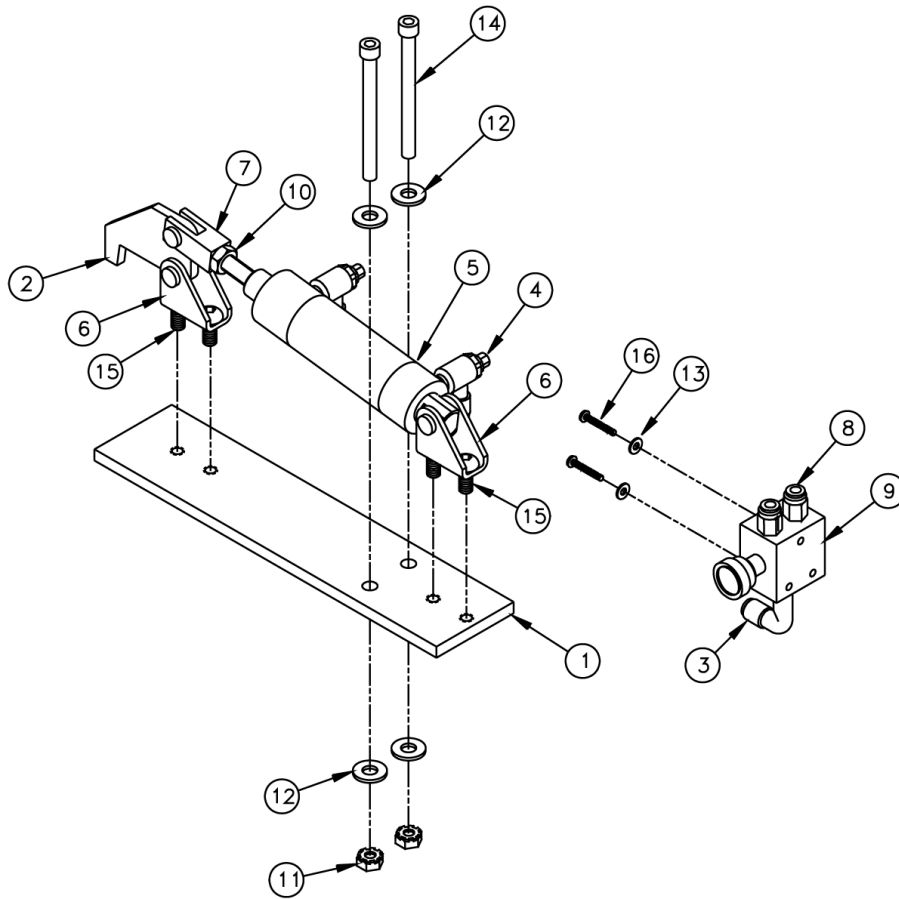

## 1335-139 Clamp & Switch Assembly

AAC Drawing Number 192468C Rev0

NO.	QTY	PART #	DESCRIPTION
1	1	1335-131	Plate
2	1	1335-133	Latch
3	1	AAQME-5-8	Male Elbow
4	2	AA198RA508	Flow Control
5	1	AAC6DP-1	Air Cylinder
6	2	AAFBP-11C	Pivot Brkt
7	1	AAFCT-11	Clevis
8	2	AAQMC-5-8	Male Connector
9	1	AAVMB43	Valve
10	1	NNJ5/16-24	Jam Nut
11	2	NNK1/4-20	Kep Nut
12	4	WWFS1/4	Flat Washer
13	2	WWFS6	Flat Washer
14	2	SSSC01176	Screw, Socket Cap
15	4	SSBC01032	Screw, Button Cap
16	2	SSPS80080	Screw, Pan Head

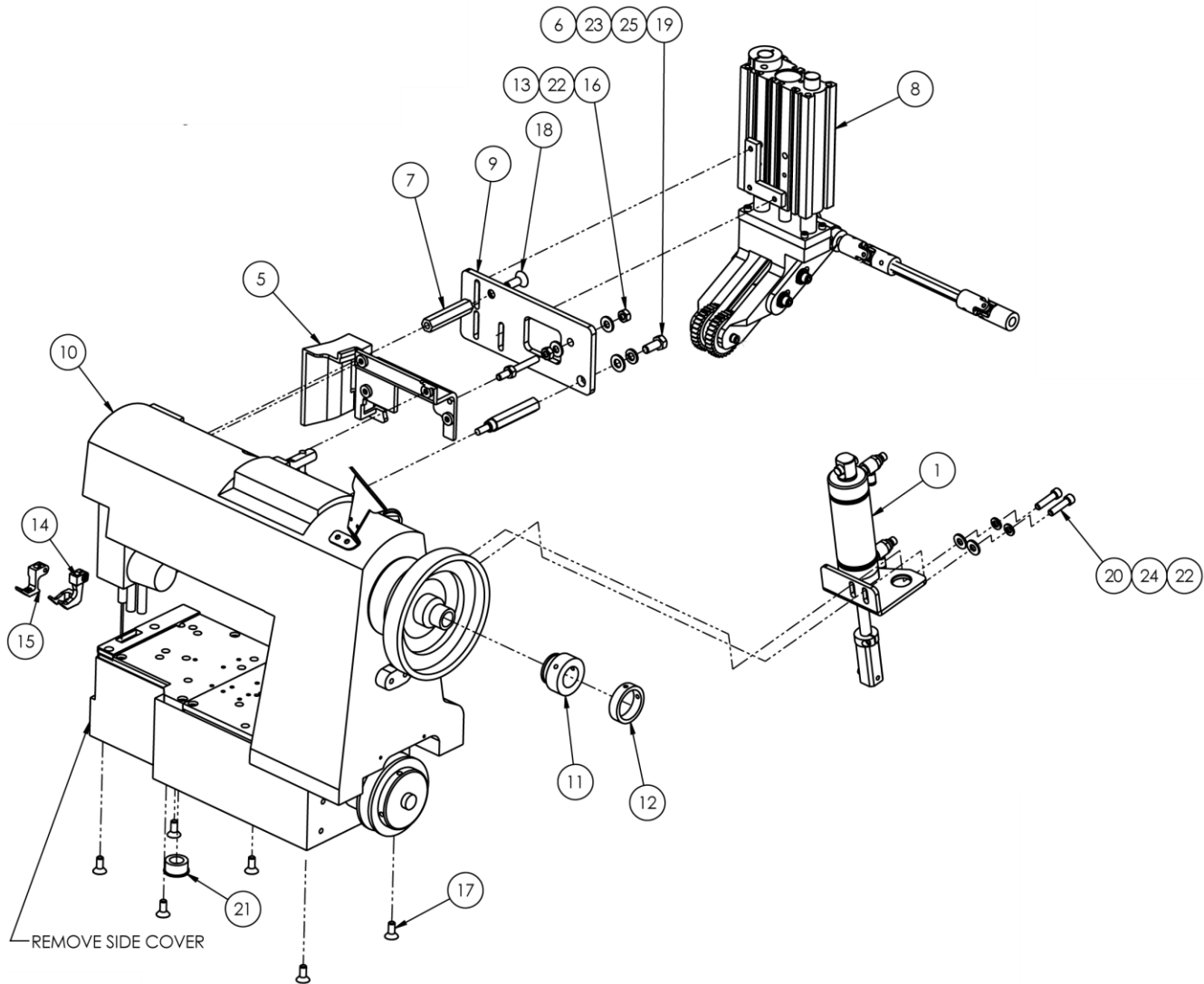

From the library of: Diamond Needle Corp

## 1335A-10 Sewing Head Assembly

AAC Drawing Number 9001052 Rev4

NO.	QTY	PART #	DESCRIPTION	NO.	QTY	PART #	DESCRIPTION
1	1	1335-110B	FOOTLIFT ASSY.	14	1	M1T31-052A	FOOT, HOLDING, RUFFLER
2	1	1335-403C	BED PLATE, LEFT, MOD	15	1	M1T31-052B	FOOT, WALKING, RUFFLER
3	1	1335-404	PLATE, THROAT	16	3	NNH1/4-20	1/4-20 HEX NUT
4	1	1335-405A	PLATE, BED, RIGHT, RUFFLE	17	2	SSSC01064	1/4-20 X 1 SOC CAP
5	1	1335051	Cover, Rear	18	1	SSHC10048	5/16-18 X 3/4 HHCS
6	1	1335054A	Standoff, Puller Plate	19	6	SSFC01040	1/4-20 X 5/8 FLAT ALN CAP
7	1	1335055A	Standoff, Puller Plate	20	1	SSFC10056	5/16-18X7/8 FLAT HD CAP
8	1	1335140B	PULLER ASSY,300UX5 SINGER	21	1	TA2351004-R0	RUBBER PLUG
9	1	1335412	PLATE, PULLER MNT, 1335MS	22	4	WWFS1/4	WASHER FLAT, 1/4
10	1	1335Q-10M2	SEWING HEAD, MODIFIED	23	1	WWFS5/16	WASHER, FLAT, 5/16
11	1	311-128	HUB, HANDWHEEL, TAPE MOUNT	24	2	WWL1/4	1/4 LW
12	1	311-129	SLEEVE TAPE MOUNT ADJUST	25	1	WWL5/16	5/16 LW
13	1	AP-1883	Rod, Threaded				



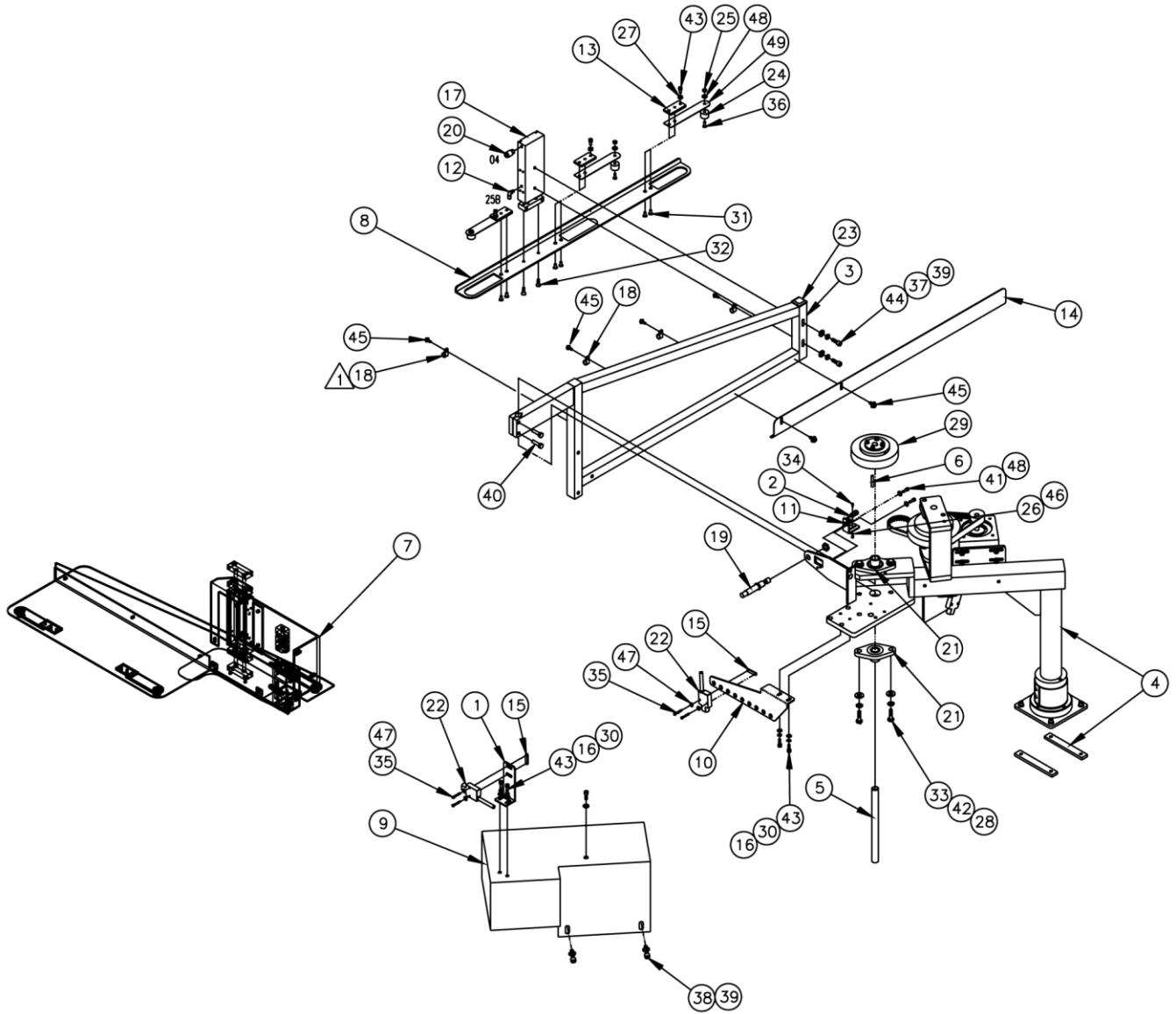



# 1335A-200 Rotate Assembly

AAC Drawing Number 192764C Rev5

NO.	QTY	PART #	DESCRIPTION
1	1	1278-6689B	Eye Mount
2	1	1278-7055B	Prox Switch
3	1	132556-213D	Rotate Arm
4	1	132556-215	Rotate Sub-Assy
5	1	1335252	Drive Shaft
6	1	132556-248	Key Stock
7	1	132556-270	Front Clamp Assy
8	1	132556-251C	Clamp Rail
9	1	1325005	Pulley Cover
10	1	132556-263B	Sensor Brkt
11	1	132556-268A	Switch Brkt
12	1	AAQME-4-10	Male Elbow
13	3	132556-281	Clamp Spring
14	1	132556-282	Bumper Shield
15	2	1975-412A	Nut Plate
16	4	WWL10	Lock Washer
17	1	AACXSM20100	Air Cylinder
18	4	AAF1/8	Plastic Clamp
19	1	AAPR025IF2B	Shock Absorber
20	1	AAQMC-5-10	Male Conn.
21	2	BBVF2S-110	Flange Bearing
22	2	FFSM312LVQ	Electric Eye
23	1	MM132-1202	End Cap
24	3	MM9540K22	Rubber Bumper
25	3	NNE8-32	Elastic Lock Nut
26	1	NNH2-56	Hex Nut
27	3	NNK10-32	Kep Nut
28	4	WWFS3/8	Flat Washer
29	1	1335277	Pulley
30	4	WWFS10	Flat Washer
31	6	SSBC98024	Screw, Button Cap
32	2	SSFCM5X14	Screw, Flat Allen
33	4	SSHC25064	Screw, Hex Cap
34	1	SSPS50032	Screw, Pan Head
35	4	SSPS70048	Screw, Pan Head
36	3	SSPS90032	Screw, Pan Head
37	2	WWL1/4	Lock Washer
38	3	SSSC01024	Screw, Socket Cap
39	5	WWFS1/4	Flat Washer
40	2	SSHC01064	Screw, Hex Cap
41	2	SSSC90032	Screw, Socket Cap
42	4	WWL3/8	Lock Washer
43	7	SSSC98032	Screw, Socket Cap
44	2	SSSCM6X40	Screw, Socket Cap
45	6	SSZS93032	Screw, Sheet Metal
46	1	WWF2	Flat Washer
47	4	WWF4	Flat Washer
48	5	WWF8	Flat Washer
49	3	132556-280	Spring

From the library of: Diamond Needle Corp

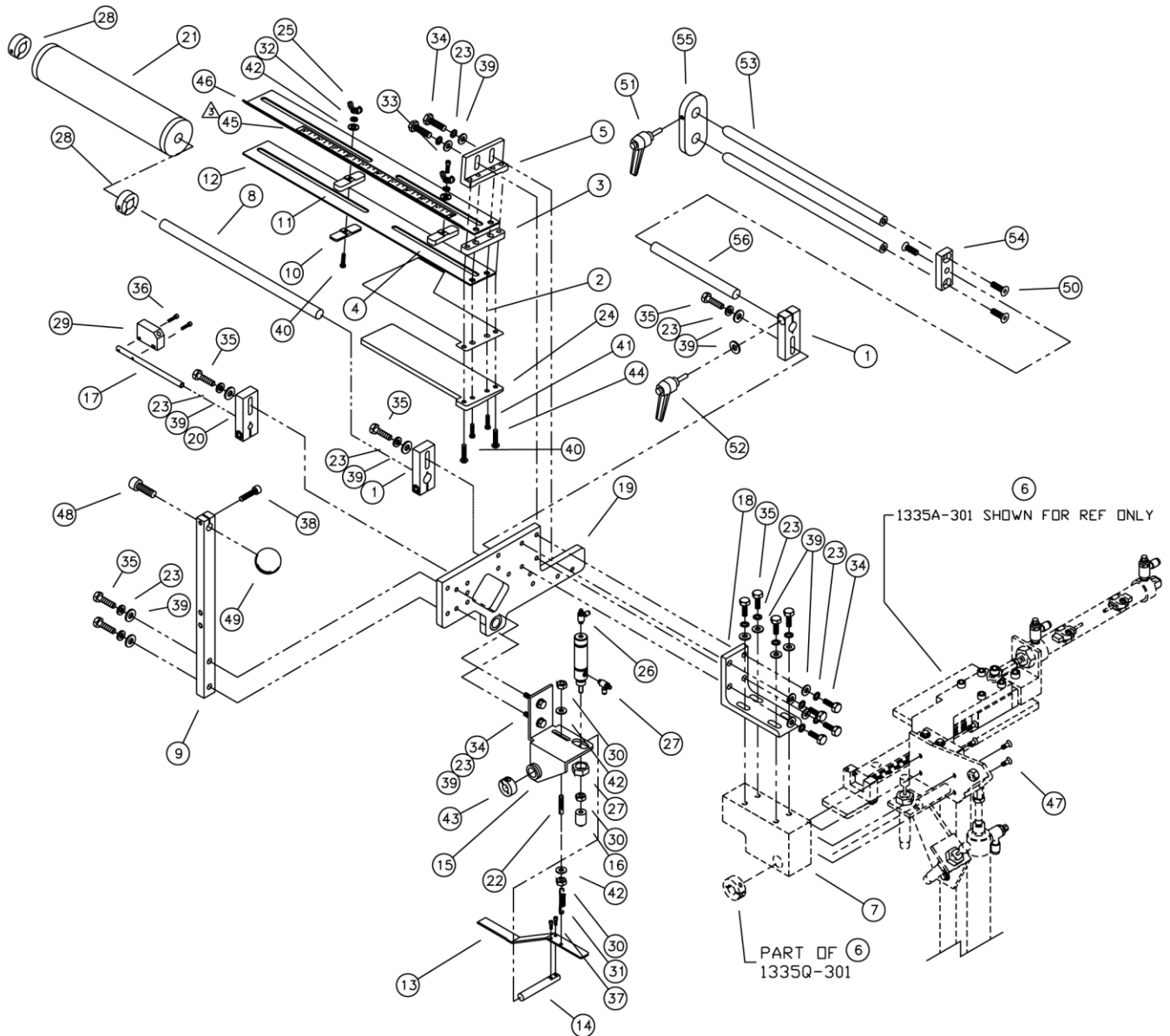

# 1335A-300 Folder Assembly

AAC Drawing Number 190128A Rev3

NO.	QTY	PART #	DESCRIPTION	NO.	QTY	PART #	DESCRIPTION
1	2	1325-346	Rod Holder	29	1	FF23SN6LVQ	Electric Eye
2	1	1325-3773D	Stripper Blade	30	3	NNH10-32	Hex Nut
3	1	A-2216D44	Spacer	31	1	RRLE018B1	Spring
4	1	A-2216D53	Spacer	32	2	WWL10	Lock Washer
5	1	1325-4449E	Folder Mnt Angle	33	1	SSSC98032	Socket Cap
6	REF	1335B-301	Folder Slide/Pivot Assy	34	8	SSHC01048	Screw, Hex Cap
7	REF	1335-302D	Pivot Block	35	9	SSHC01064	Screw, Hex Cap
8	1	1335-344E	Rod, 1/2 x 15.12	36	2	SSPS70048	Screw, Pan Head
9	1	1335-317A	Support Arm	37	2	SSSC70024	Screw, Socket Cap
10	1	A-2216D22	T-Nut	38	1	SSSC95048	Screw, Socket Cap
11	1	A-2216D34	Guide	39	18	WWFS1/4	Flat Washer
12	1	A-2216C03	Folder Plate	40	2	SSBC98064	Screw, Button Cap
13	1	1335-327C	Actuator	41	2	SSBC01048	Screw, Button Cap
14	1	1335-327B	Mount Shaft	42	4	WWFS10	Flat Washer
15	1	1335-328A	Detector Mount	43	1	CCCL6F	Clamp Collar
16	1	1335-329	Bumper	44	1	SSBC98048	Screw, Button Cap
17	1	1335-330E	Sensor Mnt Rod	45	1	1335A-302	Folder Label
18	1	1335-342	Folder Mnt Angle	46	1	A-2216C04	Folder Top
19	1	1335-343B	Folder Mnt Plate	47	4	SSFC98032	Screw, Flat Allen
20	1	1335-330F	Rod Holder	48	1	SSSC25064	Screw, Socket Cap
21	1	1335-833	Roller	49	1	SSMBK3	Knob
22	1	A-2206A	Threaded Rod	50	3	SSFC01048	Screw, Flat Allen
23	17	WWL1/4	Lock Washer	51	1	TTH34311	Threaded Handle
24	1	A-2217M	Clamp Plate	52	1	TTH32415	Threaded Handle
25	2	NNW10-32	Wing Nut	53	1	1335-803	Pivot
26	2	AA198RA510	Flow Control	54	1	1335-319C	Tension Rod Mount
27	1	AAC8D-.5	Air Cylinder	55	1	1961-211B	Edge Guide
28	2	CCCL8F	Clamp Collar	56	1	1335-816B	Pivot

From the library of: Diamond Needle Corp

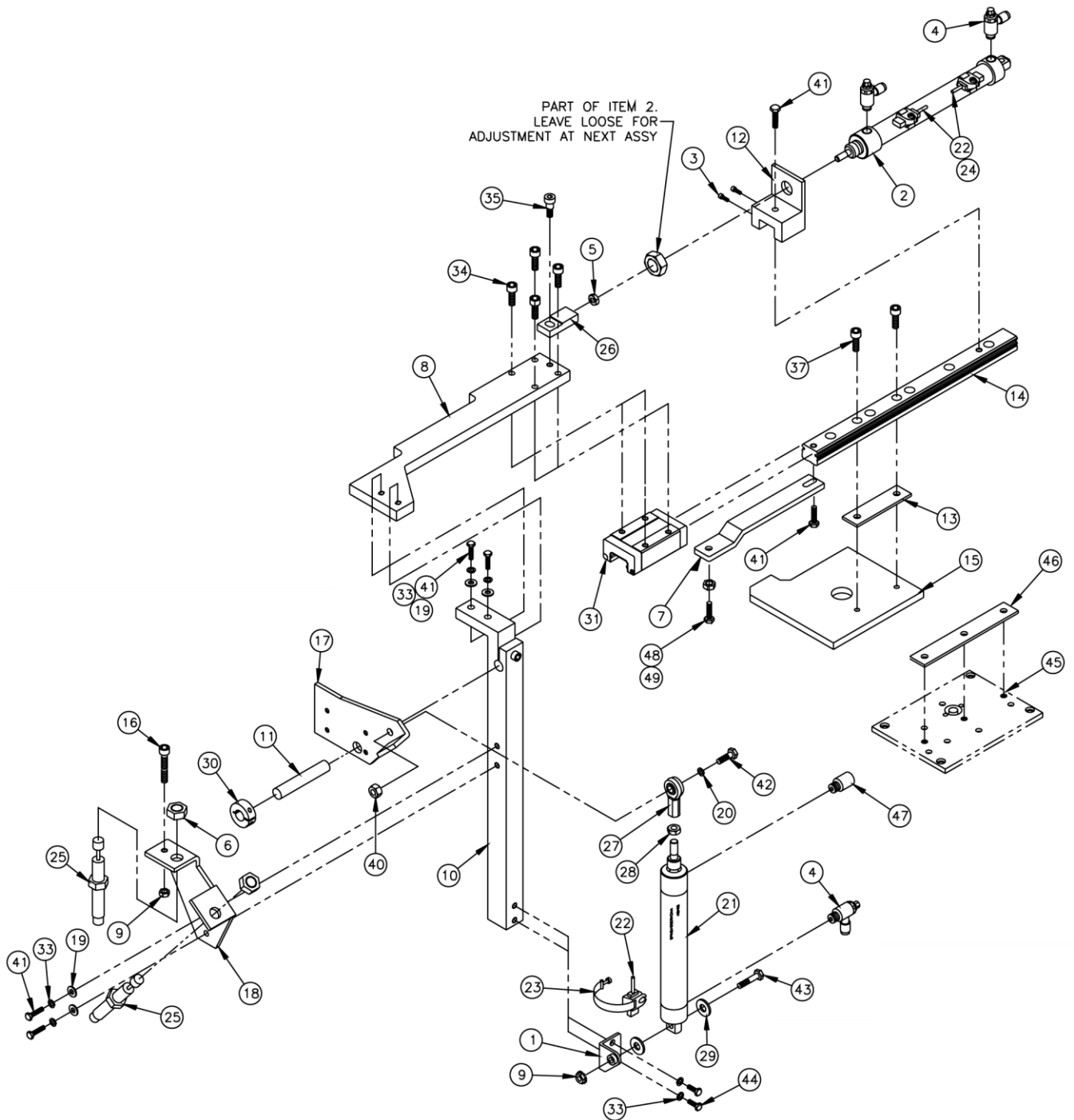

# 1335B-301 Folder Slide/Pivot Assembly

AAC Drawing Number 192843C Rev4

NO.	QTY	PART #	DESCRIPTION	NO.	QTY	PART #	DESCRIPTION
1	1	1278-6310A	Cylinder Mount	26	1	1335-345	Rod Link
2	1	AACMRS046DXPB	Air Cylinder	27	1	BBAW-5Z	Rod End
3	2	SSSC98032	Screw, Socket Cap	28	1	NNJ5/16-24	Jam Nut
4	4	AA198RR508	Flow Control	29	2	BBTT601	Thrust Washer
5	1	NNJ1/4-28	Jam Nut	30	1	CCCL8F	Clamp Collar
6	2	NNJ1/2-20	Jam Nut	31	1	MMAGH25CA	Bearing Block
7	1	1335-007B	Front Support	32	6	WWL1/4	Lock Washer
8	1	1335-301D	Extension Brkt	34	4	SSSCM6X20	Screw, Socket Cap
9	2	NNK1/4-20	Kep Nut	35	1	SSAS020024	Screw, Allen Shoulder
10	1	1335-304A	Hinge Brkt	37	2	SSSC05064	Screw, Socket Cap
11	1	1335-305	Rod	40	1	NNJ5/16-18	Jam Nut
12	1	1335-306A	Stop Block	41	6	SSHC01064	Screw, Hex Cap
13	1	1335-307	Spacer	42	1	SSHC10064	Screw, Hex Cap
14	1	MMAGR25303M1	Rail	43	1	SSHC01080	Screw, Hex Cap
15	1	1335-309	Plate	44	2	SSHC01032	Screw, Hex Cap
16	1	SSSC01096	Screw, Socket Cap	45	AR	1335-405	Plate, Mod Singer
17	1	1335-311	Pivot Brkt	46	1	1335-307A	Spacer
18	1	1335-312	Shock Mount Brkt	47	1	AAFP18	Muffler, 1/8 NPT
19	4	WWFS1/4	Flat Washer	48	1	SSHC01048	Screw, Hex Cap
20	1	WWL5/16	Lock Washer	49	1	NNH1/4-20	Nut
21	1	AACMRS094DXPB	Air Cylinder				
22	3	AAEHSKQ	Switch				
23	1	AAFD35456-10	Band For Switch				
24	2	AAFD35456-6	Band For Switch				
25	2	AAPRO25IF2B	Shock Absorber				

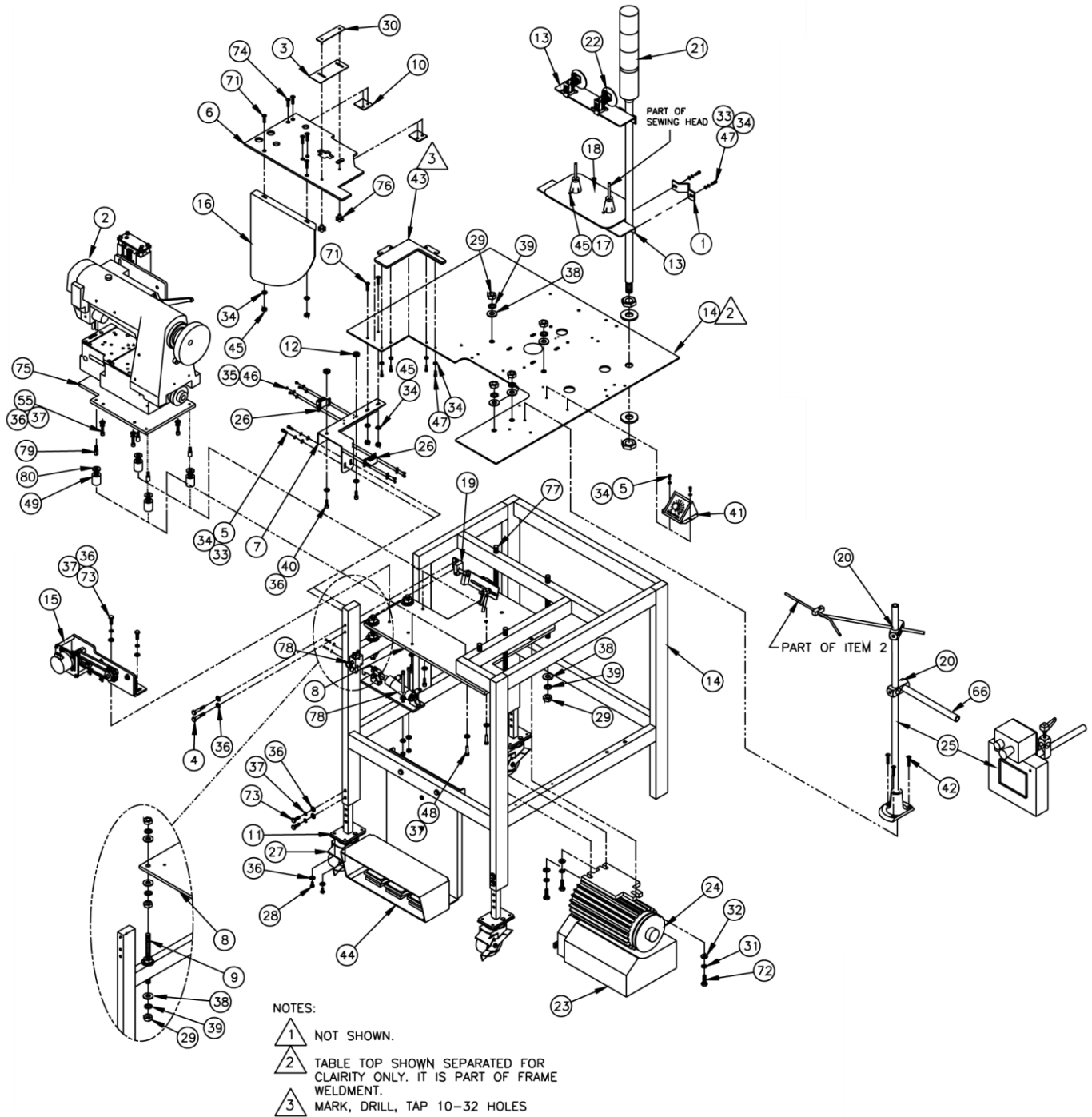

# 1335A-400 Table, Stand & Motor Assembly

AAC Drawing Number 192776C Rev3

NO.	QTY	PART #	DESCRIPTION	NO.	QTY	PART #	DESCRIPTION
1	2	0411-070	Sensor Clamp	41	1	1278-6335D	Speed Control
2	1	1335A-10	Sew Head Assy	42	3	SSFC01048	Screw, Flat Allen
3	1	1325-4421B	Edge Guide	43	1	1335-402	Table Extension
4	2	SSHC01144	Screw, Hex Cap	44	1	132556-011	Foot Pedal Assy
5	4	SSSC98024	Screw, Socket Cap	45	6	NNK10-32	Keyp Nut
6	1	132556-137G	Table Top	46	8	SSPS80016	Screw, Pan Head
7	1	132556-141A	Table Brkt, Left	47	4	SSSC98032	Screw, Socket Cap
8	1	132556-144B	Mount Plate	48	4	SSHC01064	Screw, Hex Cap
9	2	132556-145	Threaded Rod	49	4	1335-406A	Isolator Mount
10	2	132556-149A	Latch Plate	50	1	1278-6333	Cable
11	3	1961-115	Leg	51	1	1278-6335E	Cable
12	2	1335-006	Button	52	1	1278-6336B	Cable
13	2	0411-069B	Thead Brake Brkt	53	1	12788-502	Cable
14	1	1335-100	Ruffler Frame	54	1	12788-502A	Cable
15	1	132556-500C	Edge Guide Assy	55	4	SSSCM6X30	Screw, Socket Cap
16	1	1335-174	Shelf Brkt	56	1	40-312	Cable
17	2	SSPP98024	Screw, Pan Head	57	2	4003-MASBUS	Cable
18	1	1959-112	Thread Plate	58	1	4080-011A	Cable
19	1	132556-520	Edge Guide Eye Assy	59	1	0411-3014B	Cable
20	2	28201	Cross Block	60	3	4080-4508A	Cable
21	1	33001130A	Light Assy	61	1	4080-4059	Cable
22	2	4003-IS3WT2	Thread Brake Sensor	62	4	0411-3014E	Cable
23	1	4059-D7-NS	Panasonic Motor	63	1	AP-28-610R	Cable
24	1	4059-PM75	Pulley	64	1	FFKG4Z2S90	Cable
25	1	97-1700A	Touch Screen Assy	65	7	FFRK44TBS6	Cable
26	2	MM1676A12	Magnetic Catch	66	1	97-1711A	Tube
27	3	MM427-3RB	Caster	67	1	AAEC4X	Cable
28	12	SSHC01040	Screw, Hex Cap	68	2	97-1658	Cable
29	24	NNJ1/2-20	Jam Nut	69	2	97-1658A	Cable
30	1	1325-4425	Clamp Plate	70	1	0411-1919	Cable
31	3	WWL5/16	Lock Washer	71	4	SSFC98048	Screw, Flat Allen
32	3	WWFS5/16	Flat Washer	72	3	SSHC10064	Screw, Hex Cap
33	6	WWL10	Lock Washer	73	8	SSHC01048	Screw, Hex Cap
34	12	WWFS10	Flat Washer	74	4	SSFC98024	Screw, Flat Allen
35	8	WWFS6	Flat Washer	75	1	1335-407	Adaptor Plate
36	24	WWFS1/4	Flat Washer	76	2	TTCL1BPPK1	Knob
37	8	WWL1/4	Lock Washer	77	4	132556-145A	Threaded Rod
38	24	WWFS1/2	Flat Washer	78	1	1335-139	Clamp & Switch Assy
39	24	WWL1/2	Lock Washer	79	4	1335-408	Stud
40	2	SSSC01024	Screw, Socket Cap	80	4	WWU1/2	Urethane Washer

From the library of: Diamond Needle Corp



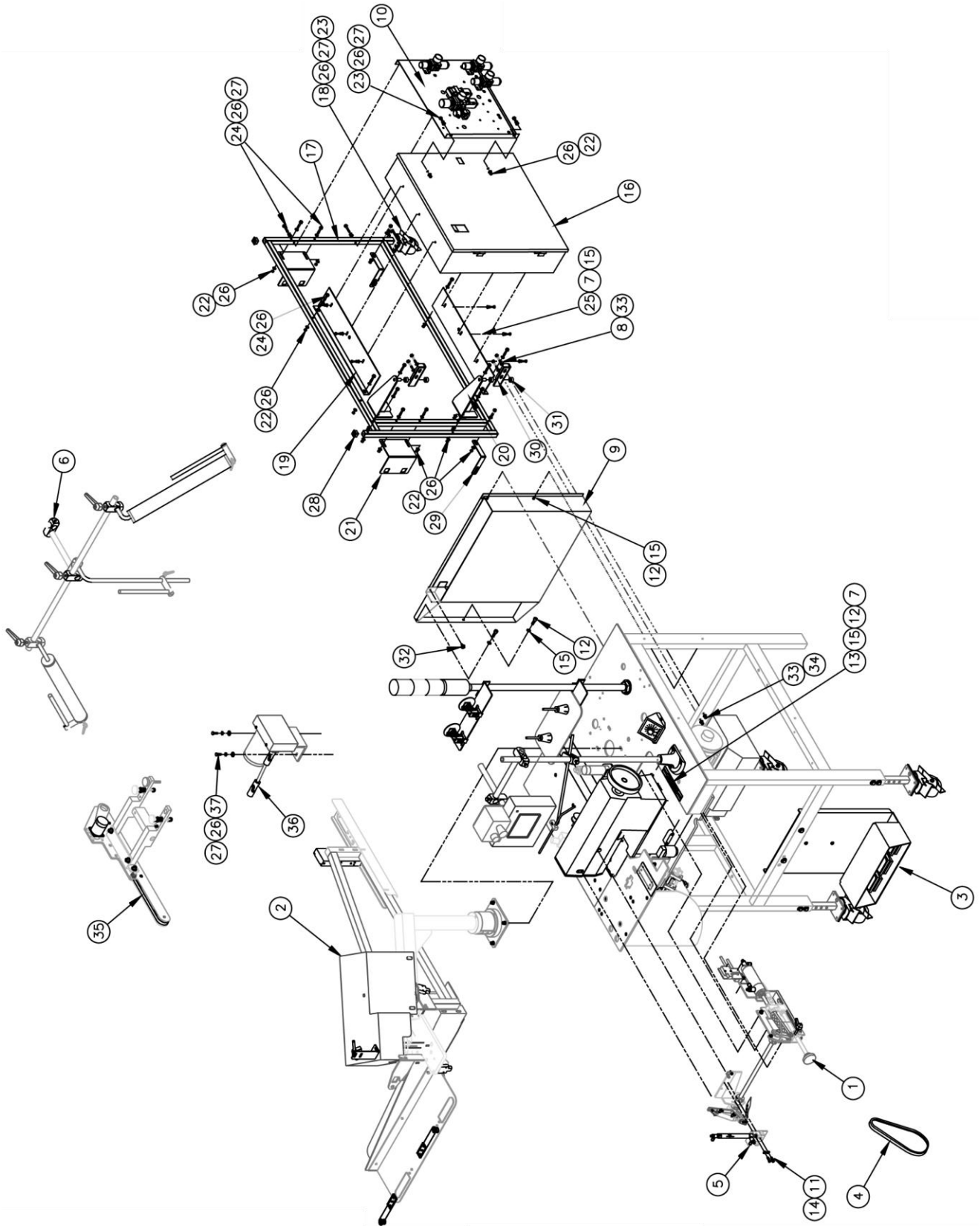



# 1335A-425 Console Assembly

AAC Drawing Number 192777C Rev5

NO.	QTY	PART #	DESCRIPTION
1	1	1335Q-02A	Ruffler Drive Assy
2	1	1335A-200	Rotate Assy
3	1	1335A-400	Table, Stand & Motor Assy
4	1	ZX3831	V Belt
5	1	1335Q-450	Thread Pull-Off Assy
6	1	1335A-430	Guide Roller Assy
7	8	WWL10	Lock Washer
8	4	SSHC10112	Screw, Hex Cap
9	1	1335A-910	Main Solenoid Panel
10	1	1335060	Pneumatic Panel Assy
11	1	SSSC90016	Screw, Socket Cap
12	6	SSSC98024	Screw, Socket Cap
13	1	1325-4127	Scale Plate
14	2	WWF8	Flat Washer
15	14	WWFS10	Flat Washer
16	1	1335070	Electrical Panel
17	1	1335180	Panel Frame
18	1	MM427-3RB	Caster
19	2	1335091	Box Support
20	2	1335170	Pivot Arm
21	2	1335074	Mount Plate
22	16	NNK1/4-20	Kep Nut
23	6	SSHC01040	Screw, Hex Cap
24	16	SSHC01096	Screw, Hex Cap
25	6	SSSC98040	Screw, Socket Cap
26	32	WWFS1/4	Flat Washer
27	4	WWL1/4	Lock Washer
28	2	MM132-1202	End Cap
29	2	1335073	Lower Leg Brkt
30	2	1335-134	Upper HInge Plate
31	2	CCCL8F	Clamp Collar
32	1	SSZS93032	Screw, Sheet Metal
33	8	WWFS5/16	Flat Washer
34	4	NNK5/16-18	Kep Nut
35	1	1335A-600	Rear Conveyor Assy
36	1	1335-120	Puller Drive Assy
37	2	SSSC01048	Screw, Socket Cap

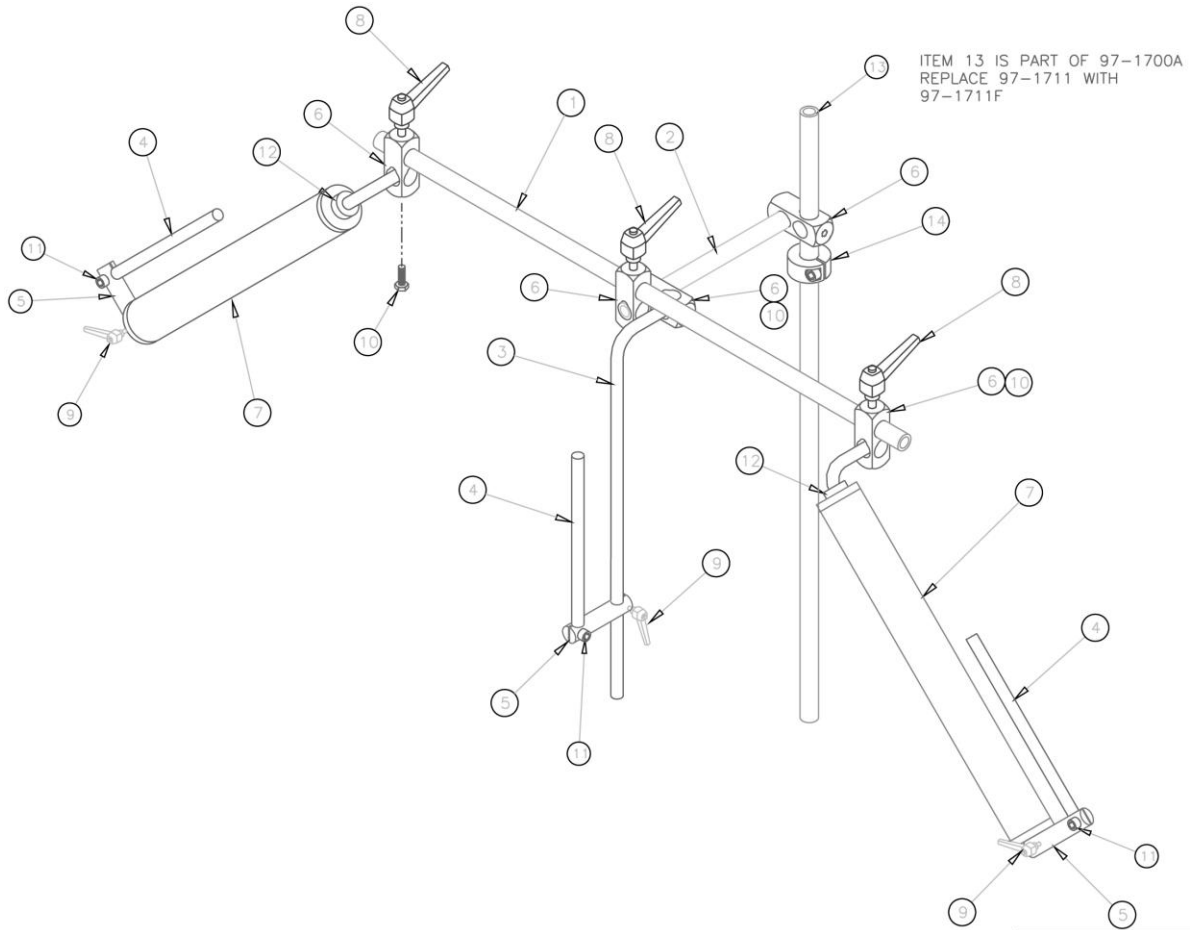

## 1335A-430 Guide Roller Assembly

AAC Drawing Number 190144A Rev4

NO.	QTY	PART #	DESCRIPTION
1	1	97-1711	Tube, 3/4 X 30
2	1	97-1711A	Tube, 3/4 x 10
3	3	1335-835	Bent Rod
4	3	8732-0576	Rod, 1/2 x 9
5	3	1335-319B	Rod Clamp, 1/2
6	5	28201	Cross Block
7	2	1335-831	Roller
8	3	TTH32425	Threaded Handle
9	3	TTH34311	Threaded Handle
10	3	SSHC10064	Screw, Hex Cap
11	3	SSSC95048	Screw, Socket Cap
12	2	CCCL8F	Clamp Collar
13	1	97-1711F	Tube, 3/4 x 40
14	1	CCCL12F	Clamp Collar

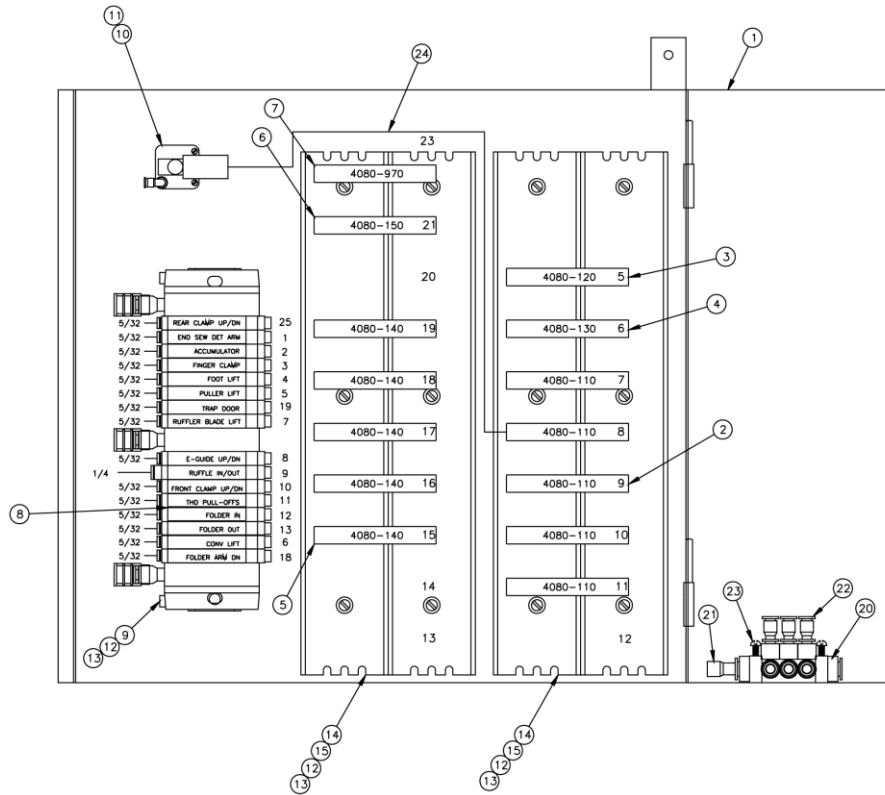

## 1335A-910 Main Solenoid Panel Assembly

AAC Drawing Number 192831C Rev2

NO.	QTY	PART #	DESCRIPTION
1	1	1335-911	Pneumatic Box
2	5	4080-110	Quad Input Module
3	1	4080-120	Dual Opto-Iso Module
4	1	4080-130	Dual Opto-Iso Module
5	5	4080-140	Quad Output Module
6	1	4080-150	Program Module
7	1	4080-970	Memory Module
8	1	1335Q-LAB1	Label
9	1	AAE1335-16	Valve Set
10	1	AAVF51FM1B	Air/Elec Switch
11	2	SSSC70024	Screw, Socket Cap
12	16	SSPS90024	Screw, Pan Head
13	16	WWF8	Flat Washer
14	5'	EEDF2X2	Wire Duct
15	5'	EEDC2X2	Wire Duct Cover
16	1	1335Q-910AWD3	Wiring Diagram
17	1	MM40450010	Slide Lock
18	1	4080-4122	Cable
19	1	1335-912	Door
20	1	AAQMF-144	Manifold
21	1	AAQPP-11	Plug
22	3	AAQPR-5-4	Reducer
23	2	SSPS90064	Screw, Pan Head
24	1	12788-503	Cable

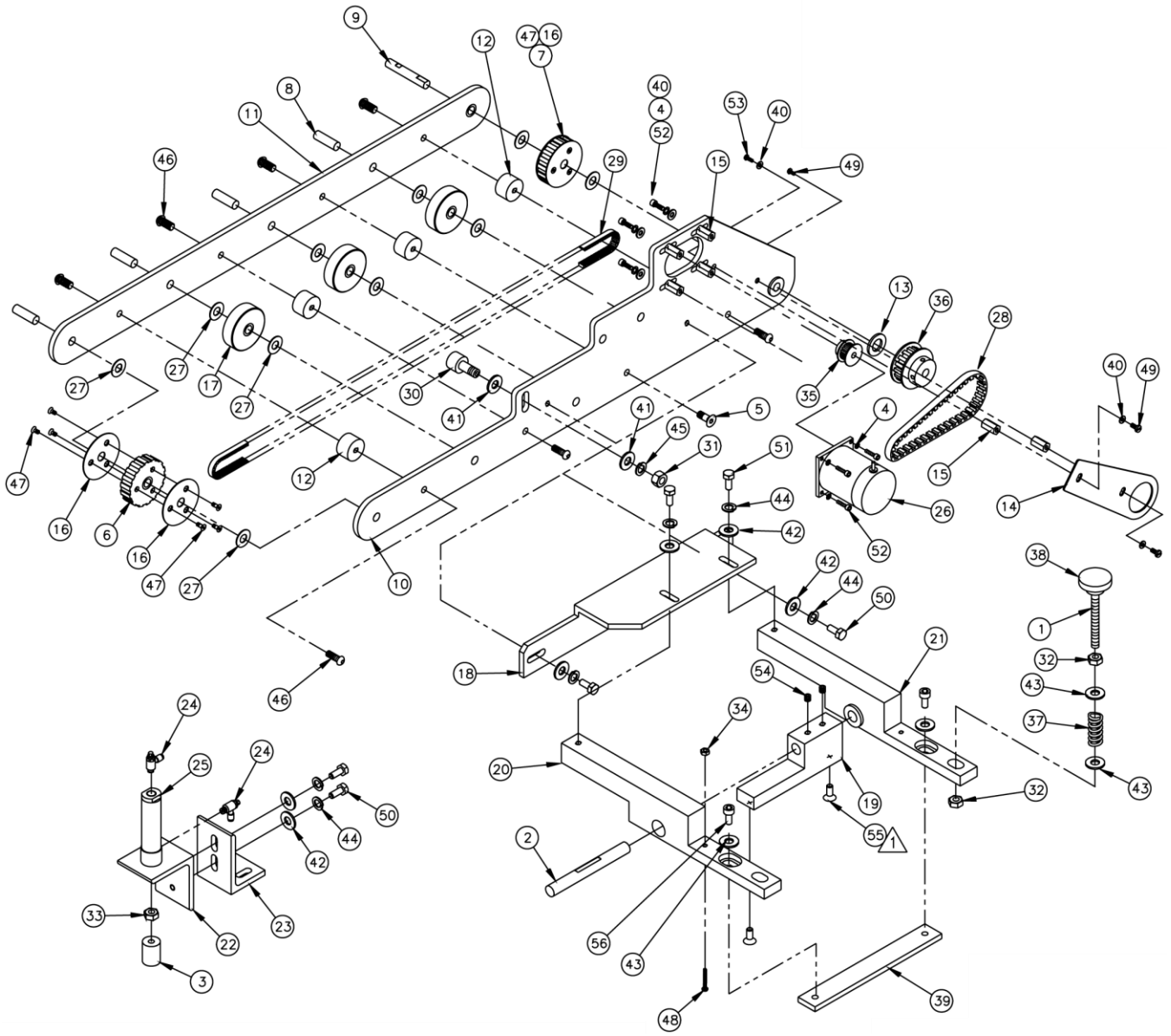

From the library of: Diamond Needle Corp

# 1335A-600 Rear Conveyor Assembly

AAC Drawing Number 192858C Rev2

NO.	QTY	PART #	DESCRIPTION	NO.	QTY	PART #	DESCRIPTION
1	1	010-054	Threaded Rod	29	1	GGD540L050	Gear Belt
2	1	1335-609	Shaft	30	1	MMCCF3/4SB	Cam Follower
3	1	11200	Bumper	31	1	NNH3/8-24	Hex Nut
4	8	WWL10	Lock Washer	32	2	NNJ5/16-18	Jam Nut
5	1	SSFC01032	Screw, Flat Allen	33	1	NNJ1/4-28	Jam Nut
6	1	1335-601	Idler Pulley	34	1	NNH10-32	Hex Nut
7	1	1335-602	Drive Pulley	35	1	PP14XL037M	Gear Pulley
8	4	1335-603	Idler Shaft	36	1	PP28XLB037	Pulley
9	1	1335-604	Drive Shaft	37	1	RRLC055G5	Spring
10	1	1335-605	Sideplate	38	1	TTK32308	Knob
11	1	1335-606	Sideplate	39	1	1335-624A	Brace
12	4	1335-607	Spacer	40	7	WWF10	Flat Washer
13	1	1335-608	Spacer	41	2	WWFS3/8	Flat Washer
14	1	1335-610	Belt Cover	42	6	WWFS1/4	Flat Washer
15	6	1335-611	Cover Standoff	43	4	WWFS5/16	Flat Washer
16	4	1335-619	Flange	44	6	WWL1/4	Lock Washer
17	3	1335-620	Roller	45	1	WWL3/8	Lock Washer
18	1	1335-621C	Angle Mount	46	7	SSBC01032	Screw, Button Cap
19	1	1335-622A	Pivot Block	47	12	SSFC70016	Screw, Flat Allen
20	1	1335-623A	Conveyor Arm	48	1	SSPS98064	Screw, Pan Head
21	1	1335-623B	Conveyor Arm	49	3	SSPS98024	Screw, Pan Head
22	1	265018	Cylinder Brkt	50	4	SSHC01040	Screw, Hex Cap
23	1	265019	Conveyor Mount	51	2	SSHC01048	Screw, Hex Cap
24	2	AA198RA508	Flow Control	52	8	SSSC98032	Screw, Socket Cap
25	1	AAC7D-1	Air Cylinder	53	1	SSPS98032	Screw, Pan Head
26	1	AP-22E-103	Stepper Motor	54	2	SSSS01016	Screw, Socket Set
27	10	BBTRA613	Thrust Washer	55	2	SSFC01040	Screw, Flat Allen
28	1	GG180XL037	Gear Belt	56	2	SSSC10040	Screw, Socket Cap

From the library of: Diamond Needle Corp

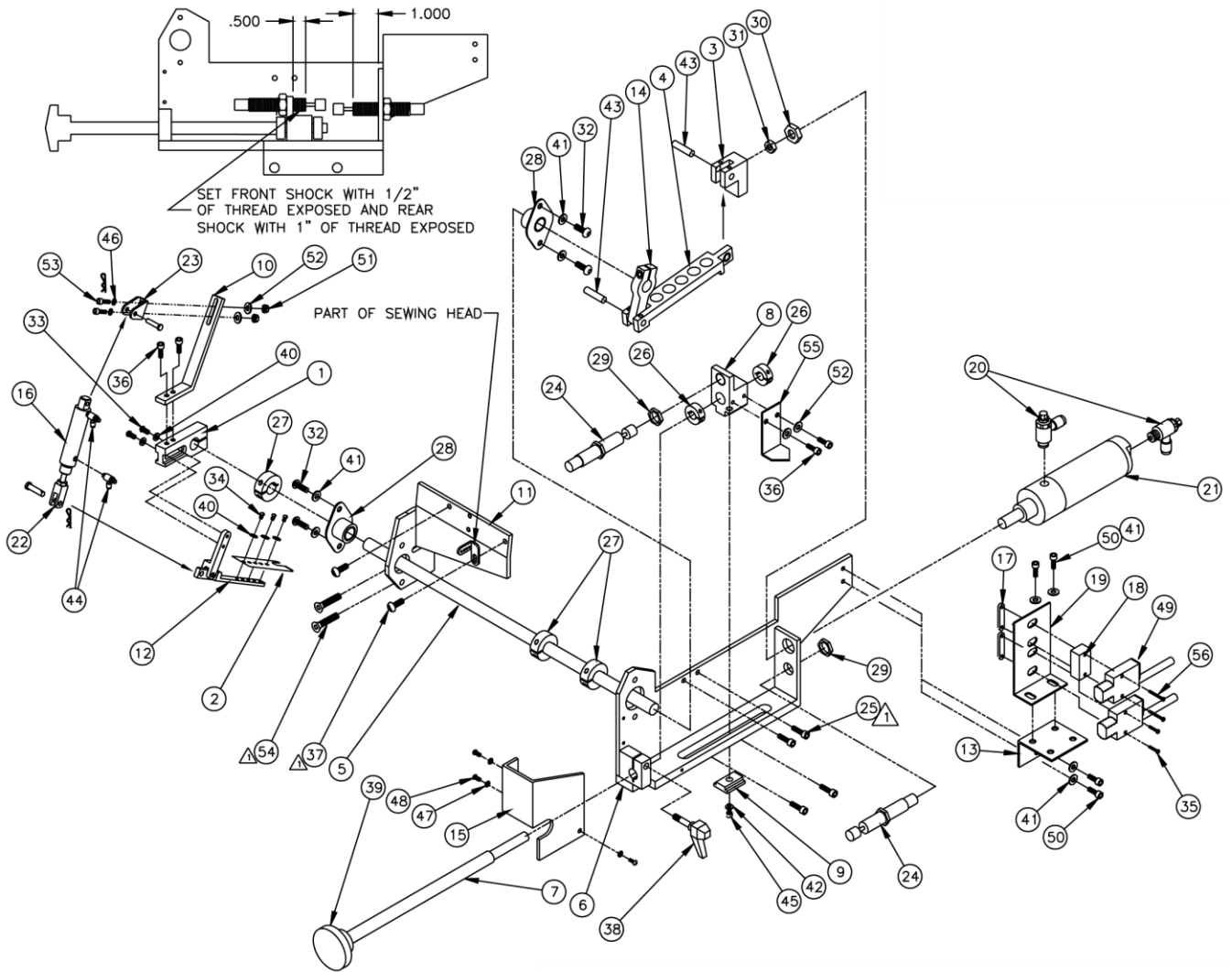

# 1335Q-02A Ruffler Drive Assembly

AAC Drawing Number 192972C Rev0

NO.	QTY	PART #	DESCRIPTION	NO.	QTY	PART #	DESCRIPTION
1	1	1325-1C	Arm	29	2	NNJ1/2-20	Jam Nut
2	1	1325-3602C	Blade	30	1	NNJ3/4-16	Jam Nut
3	1	1325-4104	Clevis	31	1	NNJ5/16-24	Jam Nut
4	1	1325-4105A	Drive Yoke	32	4	SSBC98024	Screw, Button Cap
5	1	1325-4109A	Shaft	33	2	SSSC85032	Screw, Socket Cap
6	1	1325-4113C	Mount Brkt	34	3	SSM87U	Screw, Fillister Head
7	1	1325-4114	Rod	35	4	SSPS70048	Screw, Pan Head
8	1	1325-4115A	Block	36	4	SSSC90024	Screw, Socket Cap
9	1	1325-4116	T-Nut	37	2	SSM84-566	Screw, Pan Slotted
10	1	1325-4121	Mount Arm	38	1	TTH32416	Threaded Handle
11	1	1325-5198D	Left Side Brkt	39	1	TTK32315	Torque Knob
12	1	1325-5B-6	Ruffler Arm Assy	40	5	WWB6S	Brass Washer
13	1	1325-4122	Eye Brkt Mnt	41	8	WWFS10	Flat Washer
14	1	1335-005A	Drive Arm	42	4	WWFS1/4	Flat Washer
15	1	1335-010A	Guard	43	2	IID016X064	Dowel Pin
16	1	AAC8DP-.5	Air Cylinder	44	2	AA198RA510	Flow Control
17	2	1975-412A	Nut Plate	45	1	SSSC01040	Screw, Socket Cap
18	1	1975-412C	Spacer	46	2	WWL8	Lock Washer
19	1	1325-4123	Eye Brkt	47	3	WWFS6	Flat Washer
20	2	AA198RA408	Flow Control	48	3	SSBC80024	Screw, Button Cap
21	1	AAC122-D	Air Cylinder	49	2	FFSM312LVQ	Electric Eye
22	1	AAFCT-8	Clevis	50	4	SSSC98024	Screw, Socket Cap
23	1	AAFBP-8C	Pivot Brkt	51	2	NNK8-32	Kep Nut
24	2	AAPR025IF2B	Shock Absorber	52	4	WWF8	Flat Washer
25	4	SSSCM4X10	Screw, Socket Cap	53	2	SSSC90032	Screw, Socket Cap
26	2	CCCL6F	Clamp Collar	54	2	SSFCM5X10	Screw, Flat Allen
27	3	CCCL8F	Clamp Collar	55	1	1325-4124	Scale Pointer
28	2	MMBFM500B	Bearing	56	2	SSPS70080	Screw, Pan Head

From the library of: Diamond Needle Corp

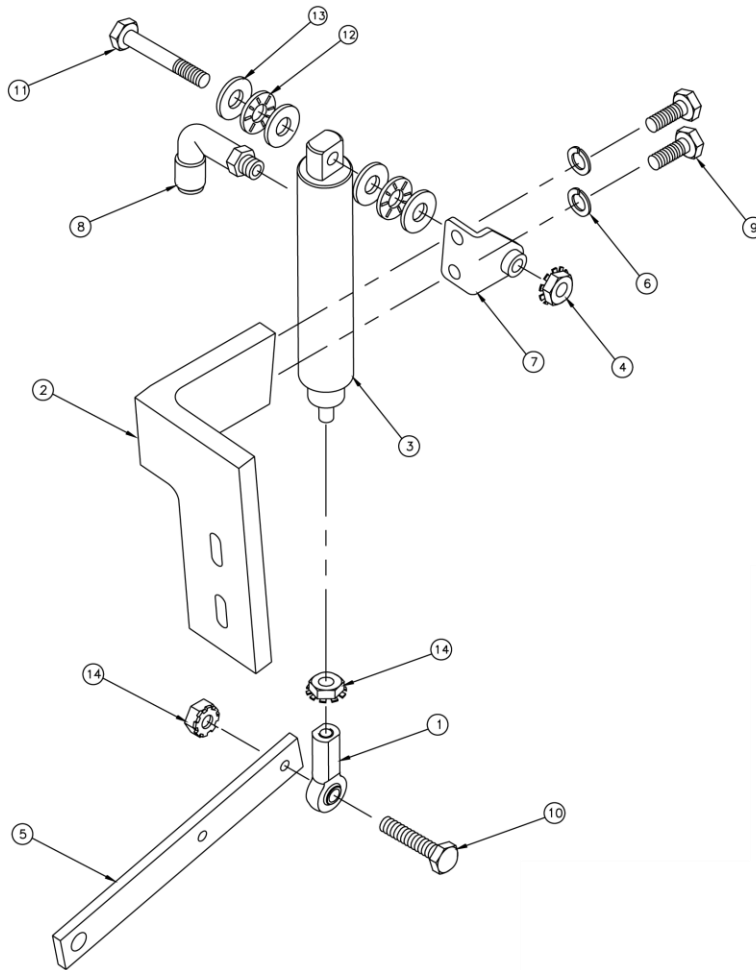

## 1335Q-110 Footlift Assembly

AAC Drawing Number 192590C Rev1

NO.	QTY	PART #	DESCRIPTION
1	1	BBAW-5Z	Rod End Bearing
2	1	1335-413	Footlift Brkt
3	1	AAC6DP-2	Air Cylinder
4	1	NNK1/4-20	Kep Nut
5	1	1335-409	Footlift Lever
6	2	WWL1/4	Lock Washer
7	1	1278-6310	Cylinder Mount
8	1	AAQME-5-8	Male Elbow
9	2	SSHCO1032	Screw, Hex Cap
10	1	SSHCO10064	Screw, Hex Cap
11	1	SSHCO1080	Screw, Hex Cap
12	2	BBNTA411	Thrust Bearing
13	4	BBTRA411	Thrust Washer
14	2	NNK5/16-18	Kep Nut



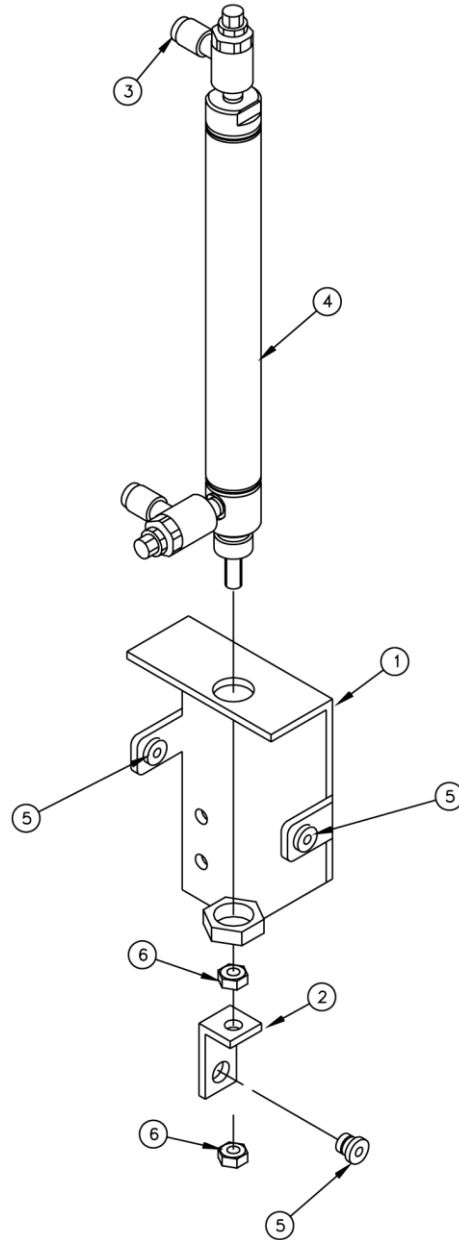

From the library of: Diamond Needle Corp

## 1335Q-450 Thread Pull-off Assembly

AAC Drawing Number 192596C Rev0

NO.	QTY	PART #	DESCRIPTION
1	1	1335-453B	Top Cylinder Brkt
2	1	1335-456	Top Thread Puller
3	2	AA198RA510	Flow Control
4	1	AACNR024-D	Air Cylinder
5	3	MMJ510	Eyelet
6	2	NNH10-32	Hex Nut

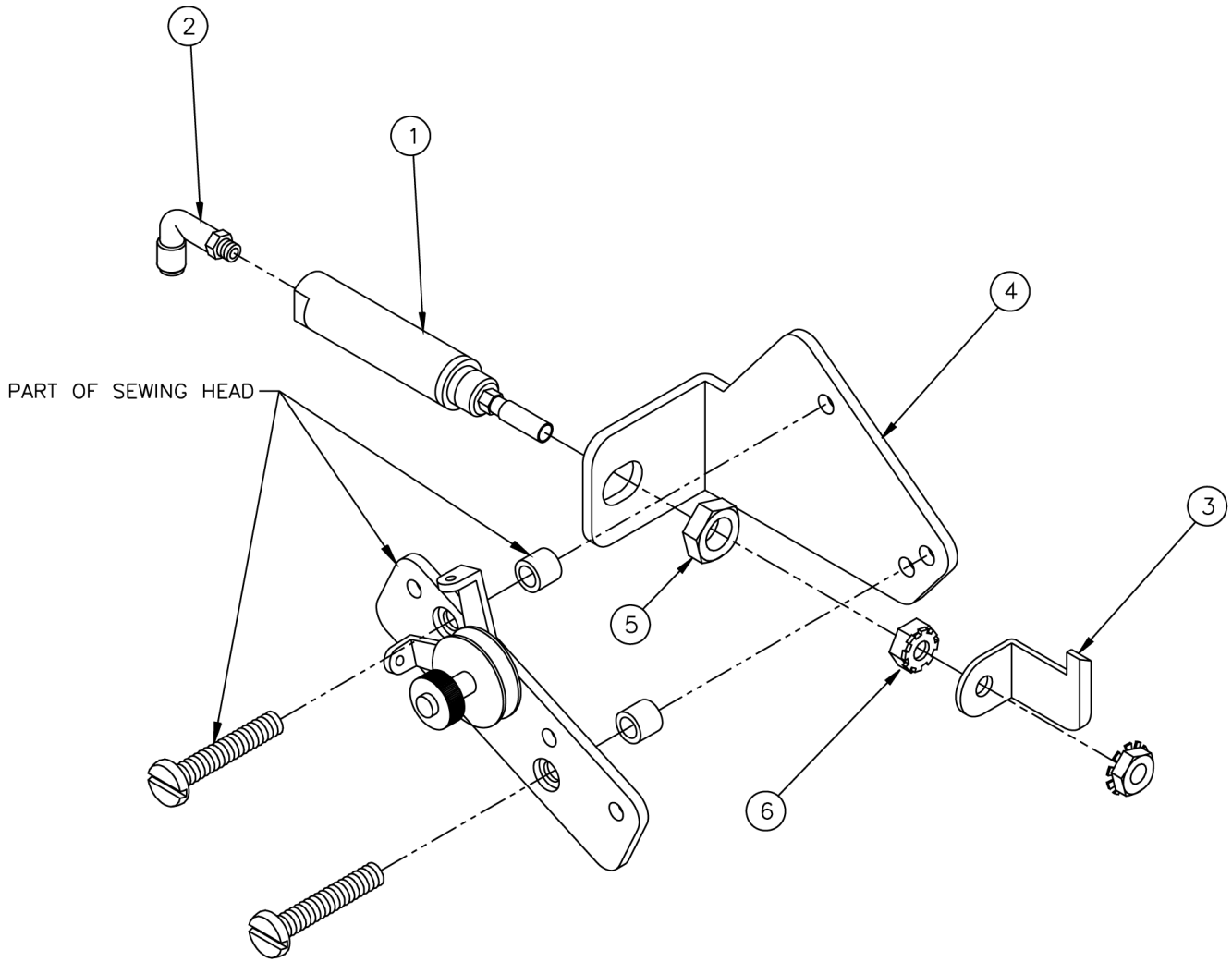

From the library of: Diamond Needle Corp

## 1335Q-460 Tension Opener Assembly

AAC Drawing Number 192597C Rev0

NO.	QTY	PART #	DESCRIPTION
1	1	AAC8SH-.5	Cylinder
2	1	AAQME-5-10	Male Elbow
3	1	1325-4440	Tension Release Finger
4	1	1325-4441	Mount
5	1	NNJ3/8-24	Jam Nut
6	2	NNK10-32	Kep Nut

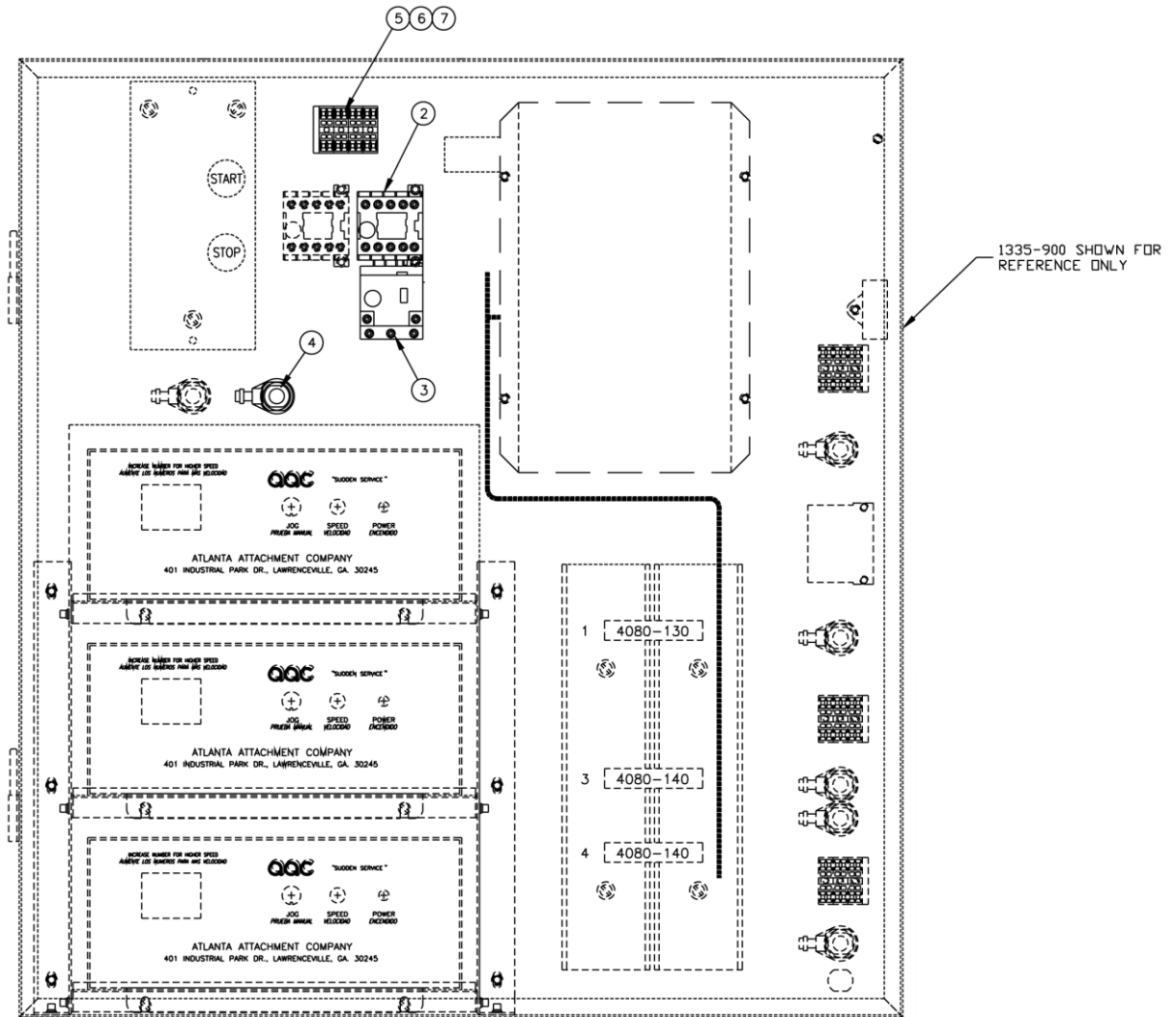

## 1335Q-900A Main Electrical Panel, Mod.

AAC Drawing Number 192654C Rev0

NO.	QTY	PART #	DESCRIPTION
1	1	1335Q-900AWD1	Wiring Diagram
2	1	EECA491024	Contactor
3	1	EECT460	Thermal Relay
4	1	FF1724	Strain Relief
5	3	FF264-341	Wago, Grey
6	1	FF264-347	Wago, Green
7	1	FF264-371	Wago, End
8	3'	FF3077-1	White Wire
9	3'	FF3077-3	Red Wire
10	3'	FF3077-6	Blue Wire
11	3'	FF3077-7	Brown Wire
12	1	FFHBL4579C	Connector

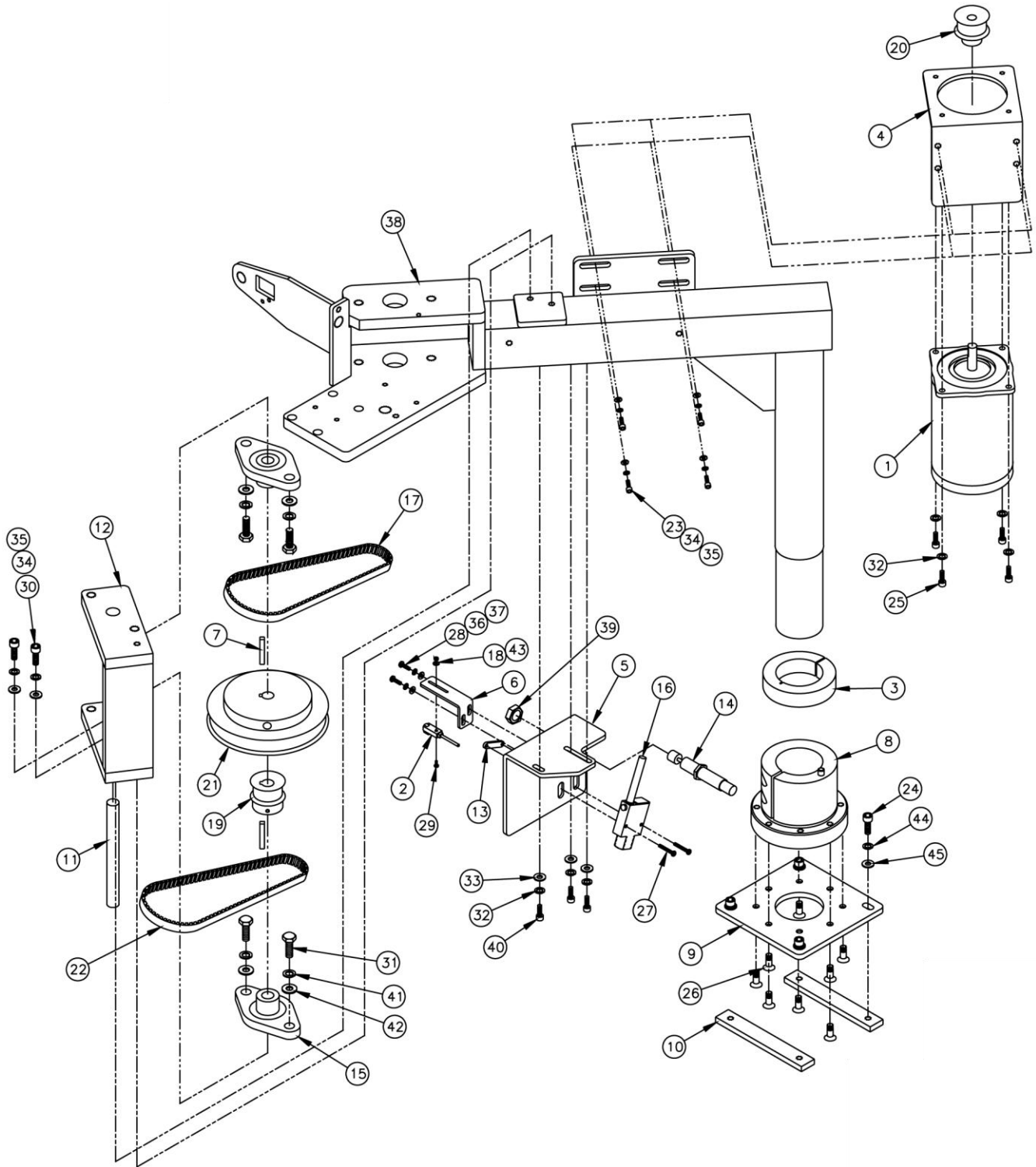

# 132556-215 Rotate Sub-Asembly

AAC Drawing Number 192433C Rev4

NO.	QTY	PART #	DESCRIPTION
1	1	011-020	Stepper Motor
2	1	1278-7055B	Prox Switch
3	1	132556-230A	Collar
4	1	132556-240	Motor Mnt Brkt
5	1	132556-241A	Shock Brkt
6	1	132556-243A	Switch Brkt
7	2	132556-248	Key
8	1	132556-260	Support Collar
9	1	132556-261	Collar Mnt Brkt
10	2	132556-262	Collar Mnt Brkt
11	1	132556-264	Shaft
12	1	132556-265	Idler Shaft Brkt
13	1	1975-412A	Nut Plate
14	1	AAPR0251F2B	Shock Absorber
15	2	BBMF2S-208	Bearing
16	1	FFSM312LVQ	Electric Eye
17	1	GG187L050	Gear Belt
18	1	NNH2-56	Hex Nut
19	1	1335254	Pulley
20	1	PP10LF050M2	Pulley
21	1	PP40LB050M1	Pulley
22	1	GG25AT10-660BFX	Gear Belt
23	4	SSSC05040	Screw, Socket Cap
24	4	SSSC10080	Screw, Socket Cap
25	4	SSSC98032	Screw, Socket Cap
26	8	SSFC01048	Screw, Flat Allen
27	2	SSPS70048	Screw, Pan Head
28	2	SSSC90032	Screw, Socket Cap
29	1	SSPS50032	Screw, Pan Head
30	2	SSSC05064	Screw, Socket Cap
31	4	SSHC25064	Screw, Hex Cap
32	7	WWL10	Lock Washer
33	3	WWFS10	Flat Washer
34	6	WWL1/4	Lock Washer
35	6	WWFS1/4	Flat Washer
36	2	WWL8	Lock Washer
37	2	WWF8	Flat Washer
38	1	132556-220A	Arm Support Assy
39	1	NNJ1/2-20	Jam Nut
40	3	SSSC98040	Screw, Socket Cap
41	4	WWL3/8	Lock Washer
42	4	WWFS3/8	Flat Washer
43	1	WWF2	Flat Washer
44	4	WWL5/16	Lock Washer
45	4	WWFS5/16	Flat Washer

From the library of: Diamond Needle Corp

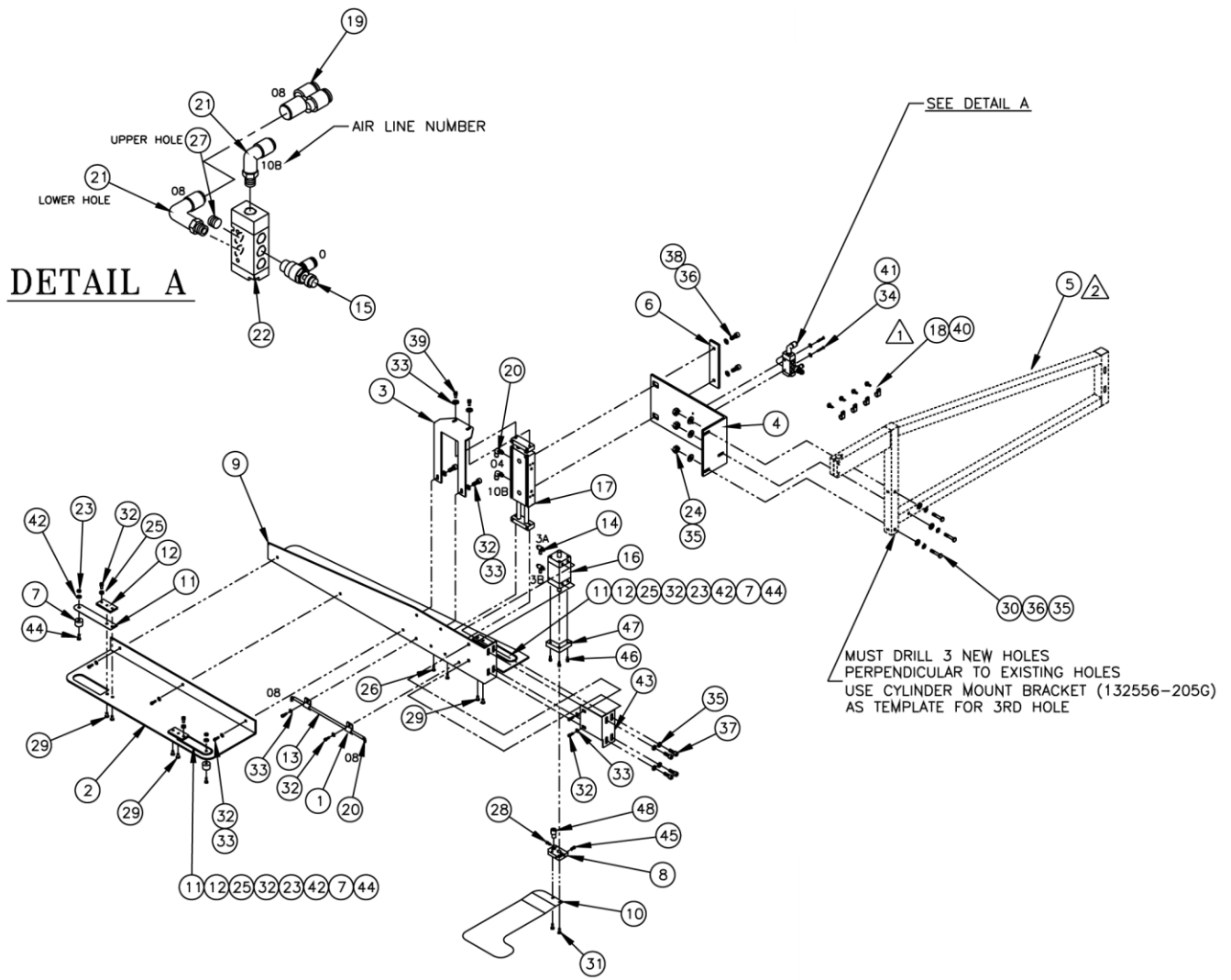

NOTES:

- 1 PLACE AS NEEDED
- 2 SHOWN FOR REFERENCE ONLY

# 132556-270 Front Clamp Assembly

AAC Drawing Number 192767C Rev5

NO.	QTY	PART #	DESCRIPTION	NO.	QTY	PART #	DESCRIPTION
1	2	0411-2126	Clamp	25	3	NNK10-32	Kep Nut
2	1	132556-277D	Front Plate	26	2	SSFCM5X14	Screw, Flat Allen
3	1	132556-277E	Front Flange Brkt	27	1	MM4554K11	Pipe Plug
4	1	132556-205G	Cylinder Mnt Brkt	28	1	SSSC98048	Screw, Socket Cap
5	REF	132556-213D	Rotate Arm	29	6	SSBC98024	Screw, Button Cap
6	1	132556-214A	Washer Plate	30	3	SSHC01112	Screw, Hex Cap
7	3	MM9540K22	Rubber Bumper	31	2	SSPS90032	Screw, Pan Head
8	1	1325021	Presser Plate Arm	32	12	SSSC98032	Screw, Socket Cap
9	1	132556-277C	Front Rotate Brkt	33	11	WWFS10	Flat Washer
10	1	132556-278B	Pressure Plate	34	2	SSPS70064	Screw, Pan Head
11	3	132556-280	Spring	35	10	WWFS1/4	Flat Washer
12	3	132556-281	Clamp Spring	36	5	WWL1/4	Lock Washer
13	1	2112-601A	Blower Tube	37	4	SSSC01048	Screw, Socket Cap
14	2	AA198RA508	Flow Control	38	2	SSSCM6X20	Screw, Socket Cap
15	1	AA198RR508	Flow Control	39	2	SSCM5X16	Screw, Cheese Head
16	1	AACS3204	Actuator Rot.	40	4	SSZS93032	Screw, Sheet Metal
17	1	AACXSWM2050	Air Cylinder	41	2	WWF4	Flat Washer
18	4	AAF1/8	Plastic Clamp	42	3	WWF8	Flat Washer
19	1	AAQUY-5-5	Union "Y"	43	1	132556-283	Brkt
20	4	AAQME-5-10	Male Elbow	44	3	SSPS90040	Screw, Pan Head
21	2	AAQME-5-8	Male Elbow	45	1	SSSC98064	Screw, Socket Cap
22	1	AAV180-4A	Pilot Valve	46	3	SSSC95040	Screw, Socket Cap
23	3	NNE8-32	Elastic Lock Nut	47	1	1325023	Bracket
24	3	NNK1/4-20	Kep Nut	48	1	1325022	Stop Pin

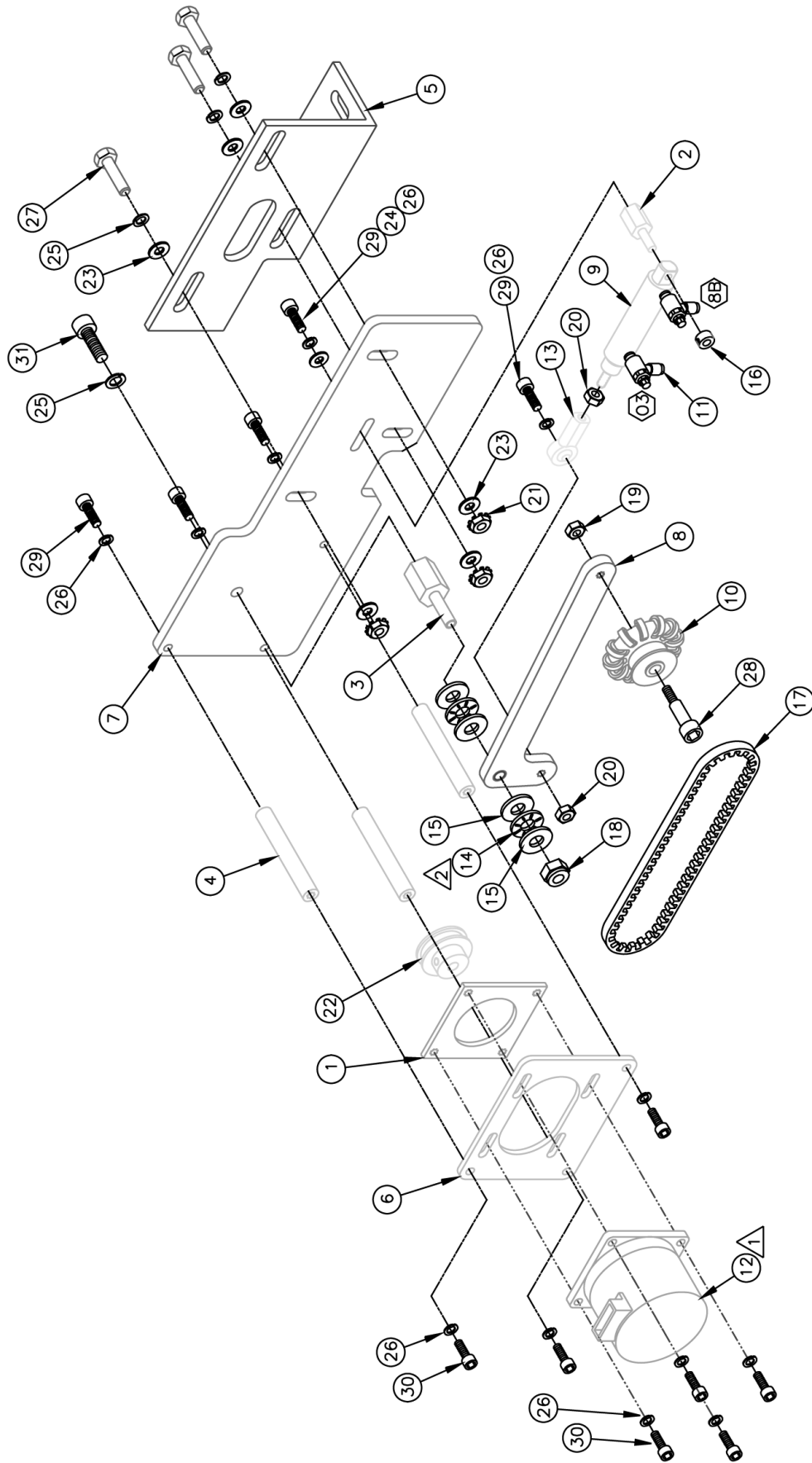



# 132556-500C Edge Guide Assembly

AAC Drawing Number 192855C Rev0

NO.	QTY	PART #	DESCRIPTION
1	1	1278-6690	Nut Plate
2	1	12787-1620	Standoff
3	1	12787-1632	Standoff
4	3	12787-1634	Standoff
5	1	132556-510	Mounting Angle
6	1	132556-511	Motor Mount
7	1	132556-512	Guide Plate
8	1	132556-513	Pivot Arm
9	1	1975-213	Air Cylinder
10	1	40-630	Guide Wheel
11	2	AA198RR510	Flow Control
12	1	AP-22E-104	Step Motor
13	1	BBAW-3Z	Rod End
14	2	BBNTA411	Thrust Bearing
15	4	BBTRA411	Thrust Washer
16	1	CCSC33/16	Set Collar
17	1	GG6R195018	Gear Belt
18	1	NNE1/4-20	Elastic Lock Nut
19	1	NNH10-24	Hex Nut
20	2	NNH10-32	Hex Nut
21	3	NNK1/4-20	Kep Nut
22	1	PP40DF1808	Gear Pulley
23	6	WWFS1/4	Flat Washer
24	1	WWFS10	Flat Washer
25	4	WWL1/4	Lock Washer
26	12	WWL10	Lock Washer
27	3	SSHC01064	Screw, Hex Cap
28	1	SSAS016064	Screw, Allen Shoulder
29	5	SSSC98048	Screw, Socket Cap
30	7	SSSC98032	Screw, Socket Cap
31	1	SSSC01048	Screw, Socket Cap

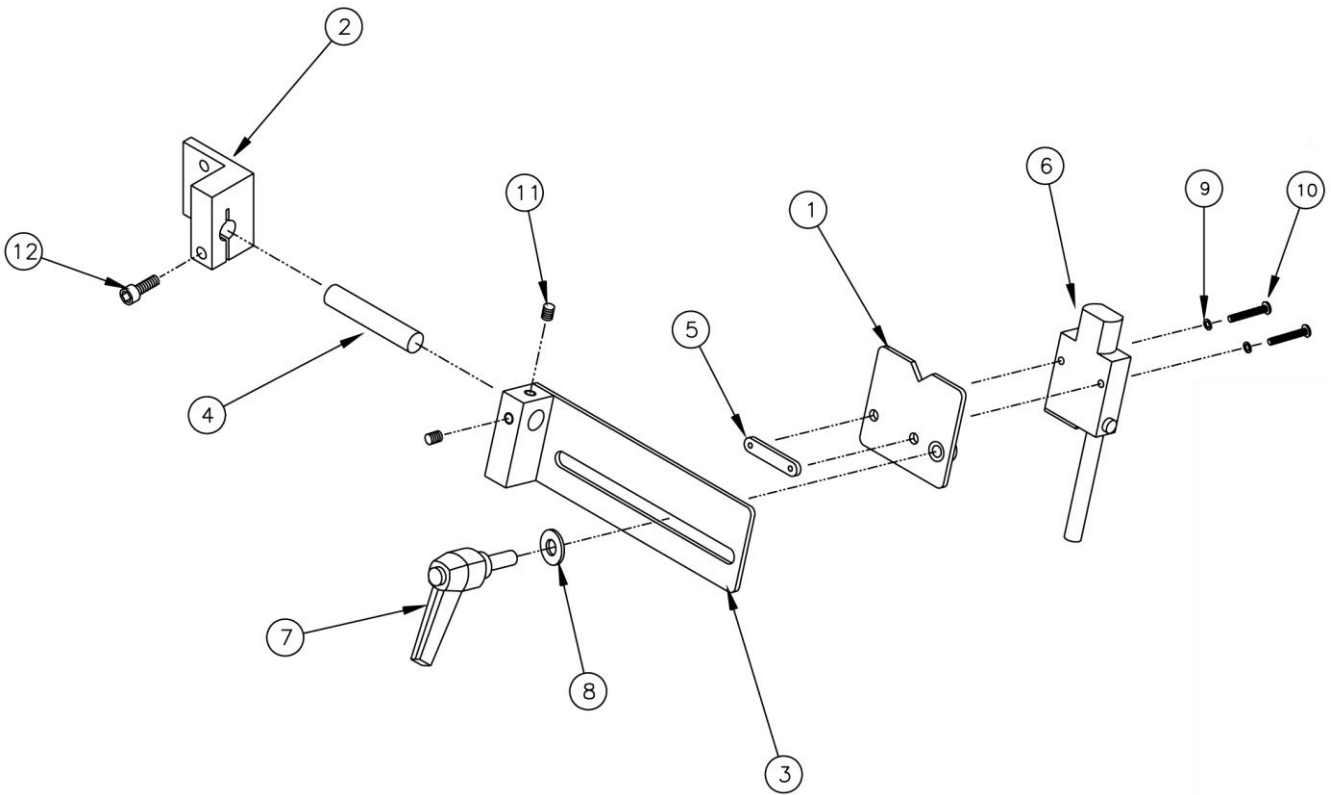

## 132556-520 Edge Guide Assembly

AAC Drawing Number 192507B Rev0

NO.	QTY	PART #	DESCRIPTION
1	1	132556-517	Eye Mount Plate
2	1	132556-518	Rod Mount
3	1	132556-519	Rod Mount
4	1	3515B-015D	Rod, 3/8 x 1.85
5	1	1975-412A	Nut Plate
6	1	FFSM312LVQ	Eye
7	1	TTH32415	Threaded Handle
8	1	WWFS1/4	Flat Washer
9	2	WWL4	Lock Washer
10	2	SSPS70048	Screw, Pan Head
11	2	SSSS98016	Screw, Socket Set
12	1	SSSC98048	Screw, Socket Cap
13	1	132556-521	Label

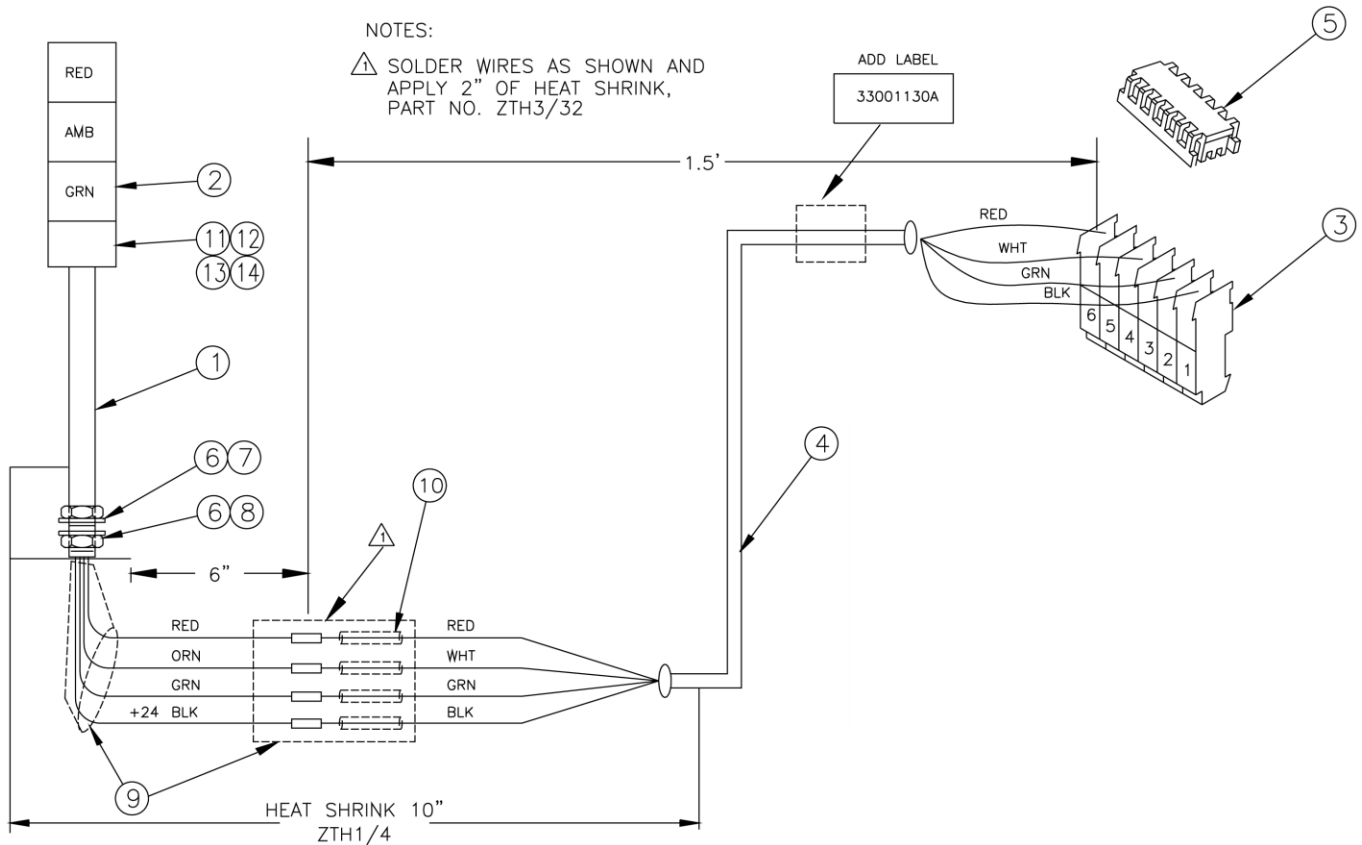

## 33001130A Light Tower Assembly

AAC Drawing Number 125791A Rev1

NO.	QTY	PART #	DESCRIPTION
1	1	33001127	Rod
2	1	EELES302	Signal Tower
3	1	FF100F2206	Connector
4	1.5'	FF36F041WA	Cable
5	1	FFSC10006	Cover, Strain Relief
6	2	NNJ3/4-16	Jam Nut
7	1	WWF3/4	Flat Washer
8	1	WWSW3/4	Spring Washer
9	10"	ZTH1/4	Heat Shrink Tube
10	2"	ZTH3/32	Heat Shrink Tube
11	1	3300102	Base
12	3	WWL4	Lock Washer #4
13	3	SSSCM3/8	Socket Cap Screw
14	2	SSSS98024	Set Screw #10

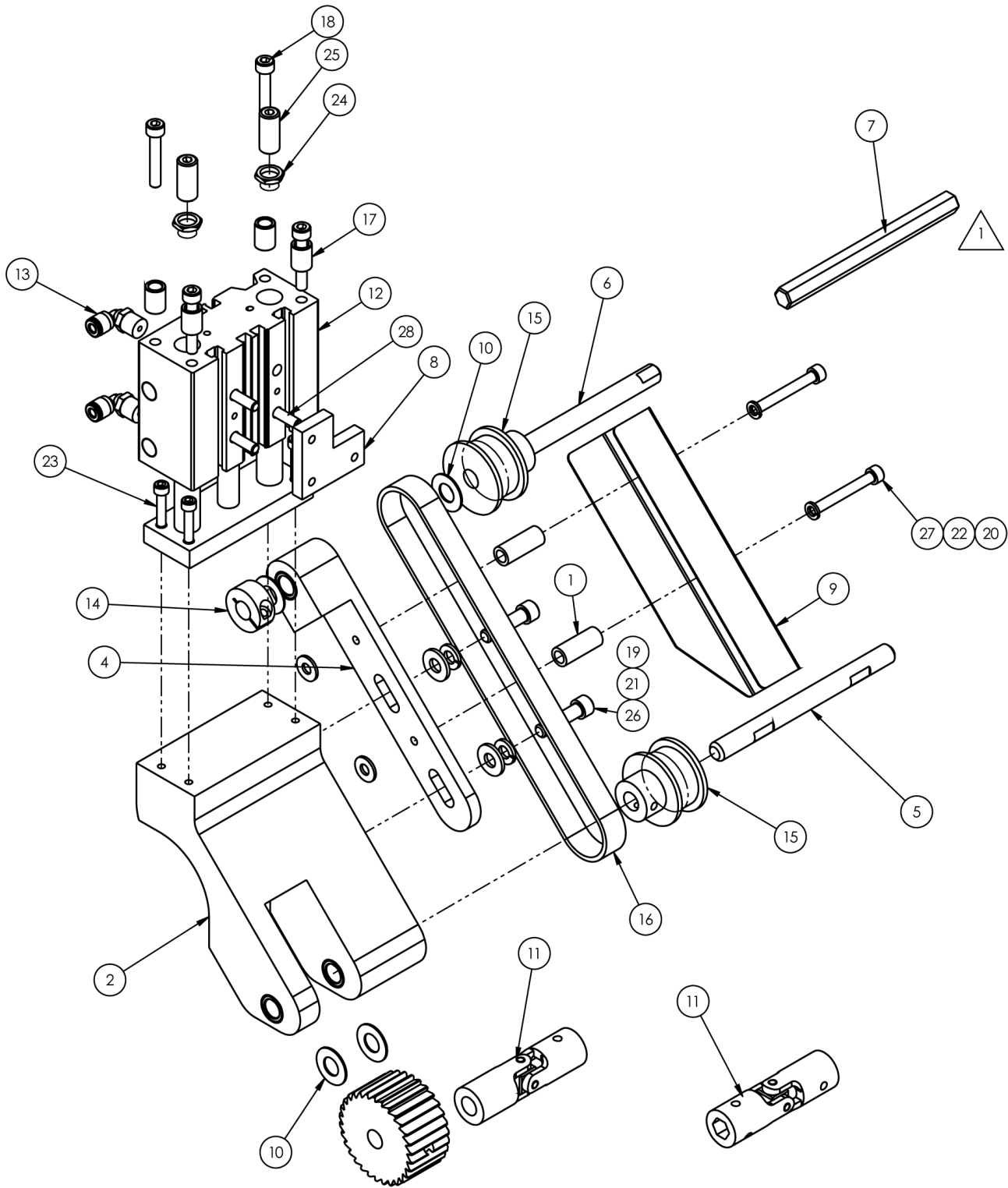

# 1335140 Puller Assembly

AAC Drawing Number 1335140 Rev2

NO.	QTY	PART #	DESCRIPTION
1	2	1335-123	SPACER, BELT GUARD
2	1	1335044	YOKE
3	1	1335045	ROLLER, FLUTTED, 1.89 OD
4	1	1335046	SUPPORT, DRIVE
5	1	1335047	DRIVE SHAFT, ROLLER
6	1	1335048	DRIVE SHAFT, TOP
7	1	1335M-121	HEX SHAFT, 3/8X4 3/8
8	1	1335053	PLATE, NUT #10-32 3PL
9	1	1335058	COVER, BELT
10	4	3517	WASHER, THRUST, BRONZE
11	2	3524-06A	U-JOINT, MODIFIED
12	1	AACMGPL2030	CYLINDER, DUAL ROD GUIDE
13	2	AAQME-M4-8	QUICK MALE ELBOW
14	1	CCCL6F	CLAMP COLLAR- 3/8
15	2	PP10LF050M2	PULLEY, GEAR, 3/8 PITCH
16	1	GG169L050	BELT, GEAR, 3/8P, 1/2W
17	4	UUAA304-2	BEARING, BRONZE, .250ID
18	4	SSSCM5X30	5MM X 30MM Lg. SHCS
19	2	WWFS1/4	1/4 FW
20	2	WWFS10	#10 FW
21	2	WWL1/4	1/4 LW
22	2	WWL10	#10 LW
23	4	SSSC90048	#8-32 X 3/4 Lg. SHCS
24	2	0411-1095	NUT, CYLINDER STOP
25	2	0411-1094	BUMPER, CYLINDER STOP
26	2	SSSC01064	1/4-20 X 1" Lg. SHCS
27	2	SSSC98096	#10-32 X 1-1/2 Lg. SHCS
28	3	SSSC98112	#10-32 X 1-3/4 Lg. SHCS

From the library of: Diamond Needle Corp

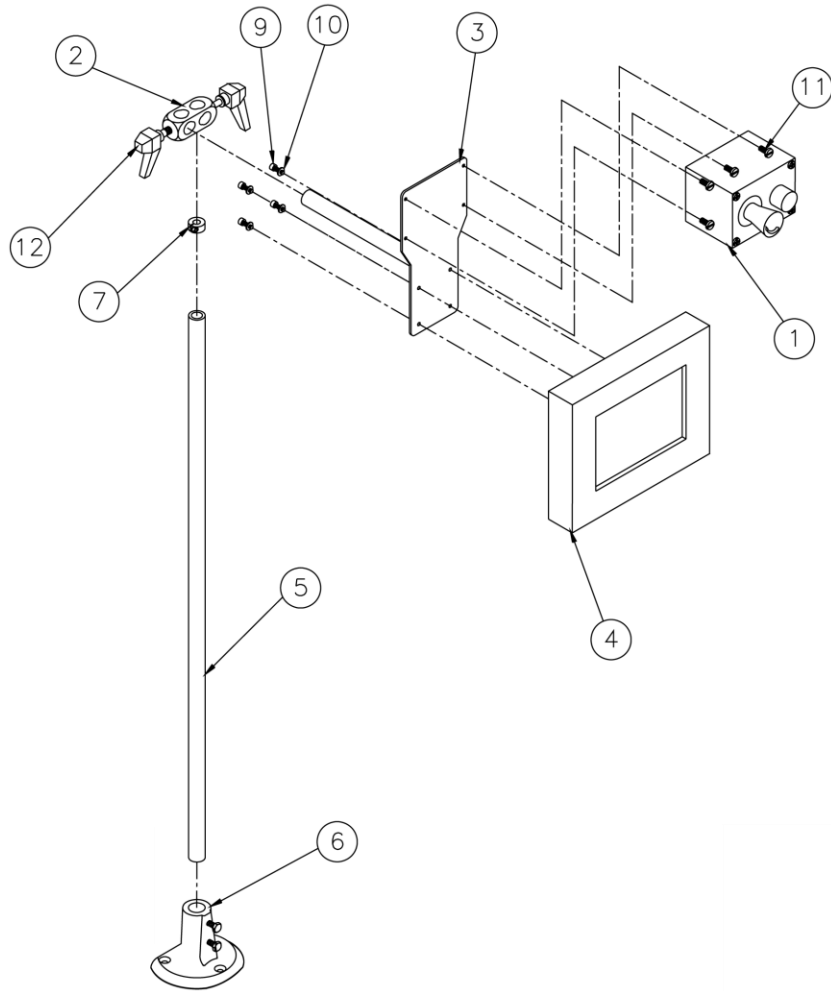

## 97-1700A Touch Screen Assembly

AAC Drawing Number 192617C Rev3

NO.	QTY	PART #	DESCRIPTION
1	1	1278-6010	Start/Stop Button
2	1	28201	Cross Block
3	1	40-112A	Touch Screen Mount
4	1	4080-003	Controller
5	1	97-1711	Tube, 3/4 x 30 x 1/8
6	1	AP-1721A	Stand Base
7	1	CCCL12F	Clamp Collar
8	10'	EE16-3C2406	Cable
9	4	SSSC80032	Screw, Socket Cap
10	4	WWL6	Lock Washer
11	4	SSPS90040	Screw, Pan Head
12	2	TTH32426	Threaded Handle

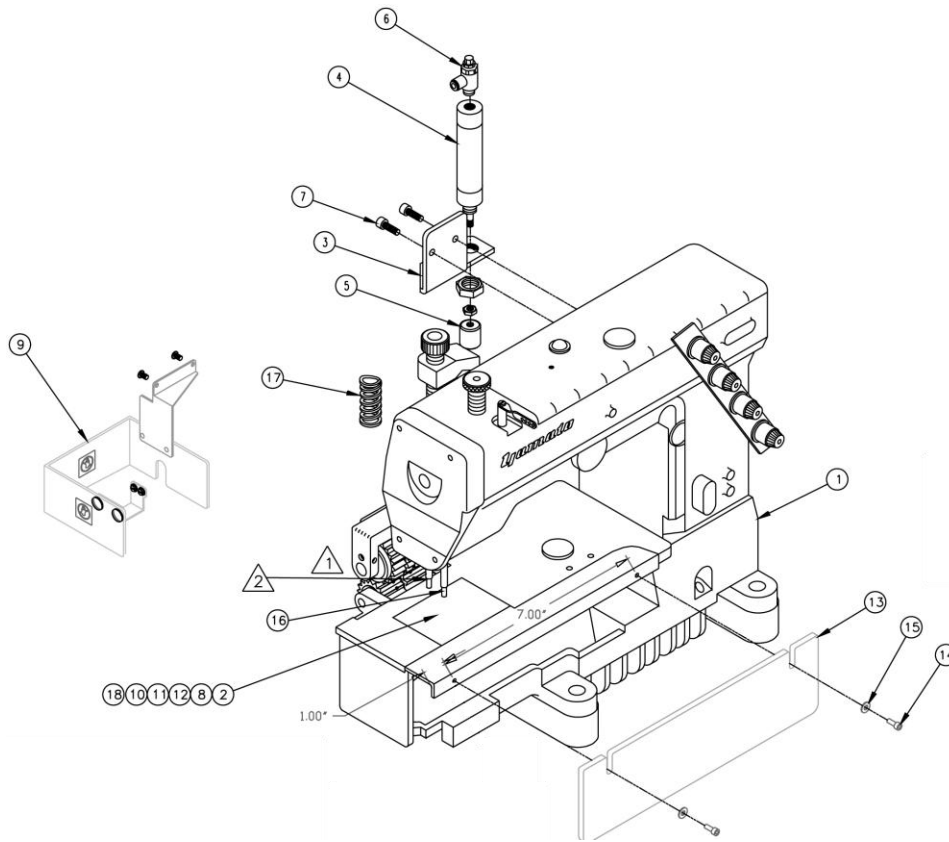

## 1334-1000A Sew Head Assembly

AAC Drawing Number 192557C Rev3

NO.	QTY	PART #	DESCRIPTION
1	1	SYAM-1804A	Yamato Sew Head
2	1	1862N94016	Needle Holder
3	1	112013	Brkt
4	1	AAC6S-1-H	Air Cylinder
5	1	11200A	Bumper
6	1	AA198RR508	Flow Control
7	2	SSSCM6X20	Screw, Socket Cap
8	1	54242B9016	Spreader
9	1	1959-412	Guard
10	1	54205A9016	Feed Dog
11	1	54420X9016	Presser Foot
12	1	54224A9016	Throat Plate
13	1	1334041	Guard
14	2	SSSC98032	Screw, Socket Cap
15	2	WWFS10	Flat Washer
16	1	3300012M	Needle Bar Mod
17	1	RRLC105J10	Puller Spring
18	1	1862N95016	Looper Holder
19	10	SN11318GB	Needle, Sys UY113,size 18

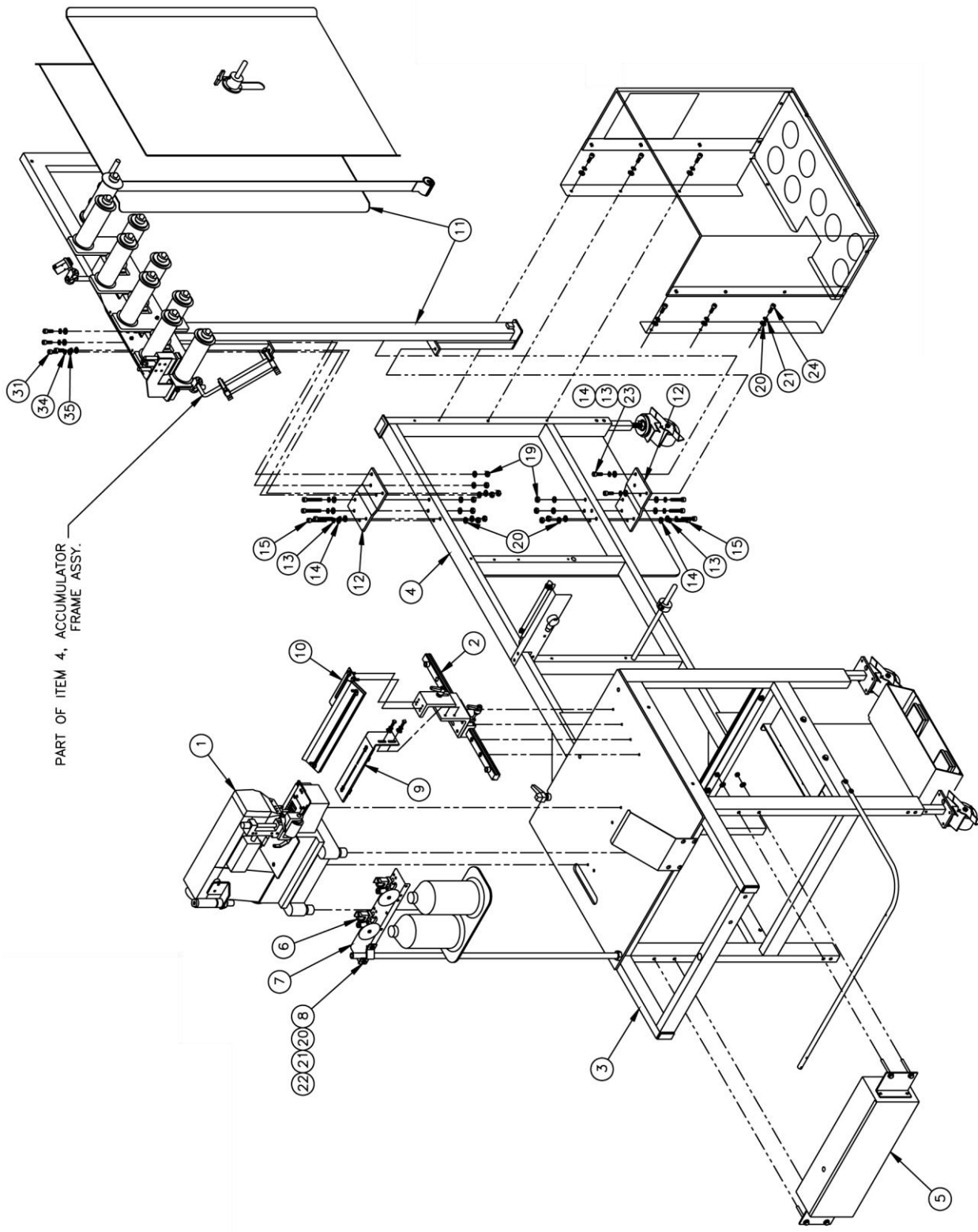



# 11334QY28A Auto Flanging Module

AAC Drawing Number 192775C Rev1

NO.	QTY	PART #	DESCRIPTION
1	1	1334-1000A	Sewing Head Assy
2	1	1334-1100C	Folder Mnt Assy
3	1	1334-2000	Frame Assy
4	1	1334-2500	Accumulator Frame Assy
5	1	1334-3000	Electrical Panel
6	2	400-3IS3WT2	Thread Brake Sensor
7	1	0411-069B	Thread Brake Detector Brkt
8	1	0411-070	Sensor Brkt Clamp
9	1	661-A19	Flange Guide
10	1	661-A18-5/16	Adjustment Guide
11	1	1335Q-800A	Accumulator Assy
12	2	1335-808A	Mount Brkt
13	14	WWL1/4	Lock Washer
14	24	WWFS1/4	Flat Washer
15	8	SSSC01128	Screw, Socket Cap
16	1	1335-900A	Main Elec Panel, Mod
17	1	1334-3000WD1	Wiring Diagram
18	1	1334-PD1	Pneumatic Diagram
19	12	NNH1/4-20	Hex Nut
20	8	WWFS10	Flat Washer
21	6	WWL10	Lock Washer
22	2	SSSC98032	Screw, Socket Cap
23	6	SSSC01064	Screw, Socket Cap
24	6	SSSC98064	Screw, Socket Cap

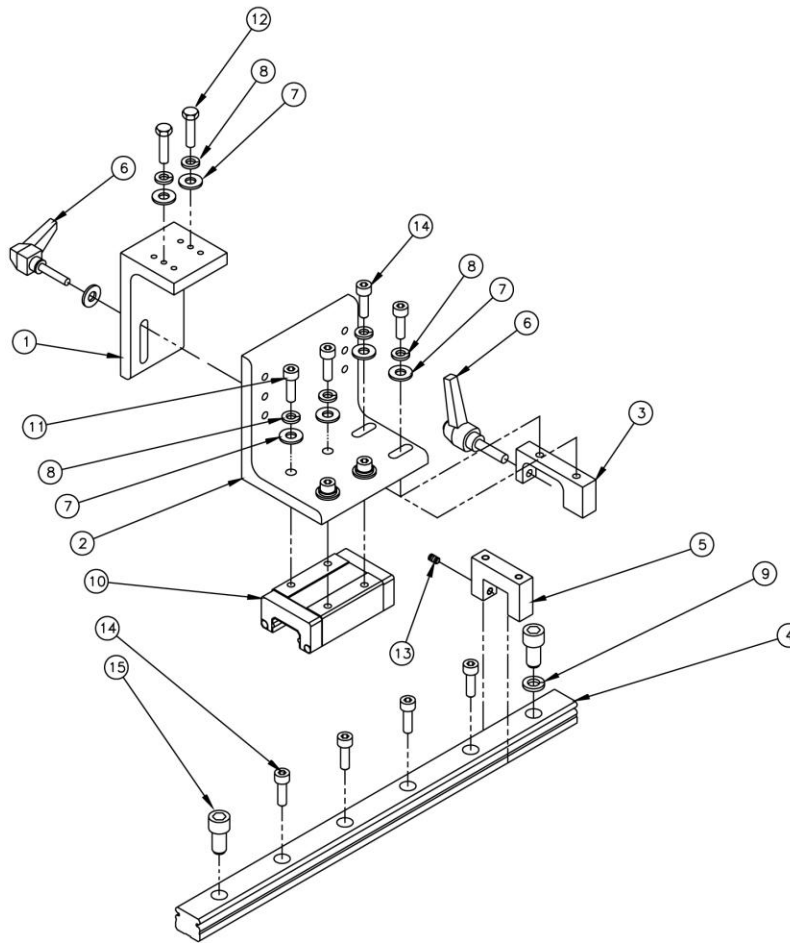

## 1334-1100C Folder Mount Assembly

AAC Drawing Number 192901C Rev2

NO.	QTY	PART #	DESCRIPTION
1	1	1334-1003	Adj. Mount
2	1	1334-1005	Lower Angle Mount
3	1	1334-1006	Lock Handle Mount
4	1	MMAGR25360M	Rail
5	1	1335-310	Stop Block
6	2	TTH32416	Threaded Handle
7	10	WWFS1/4	Flat Washer
8	10	WWL1/4	Lock Washer
9	1	WWL3/8	Lock Washer
10	1	MMAGH25CAN	Bearing Block
11	4	SSSCM6X20	Screw, Socket Cap
12	2	SSHC01040	Screw, Socket Cap
13	1	SSSS98032	Screw, Socket Set
14	6	SSSC01048	Screw, Socket Cap
15	2	SSSC25048	Screw, Socket Cap

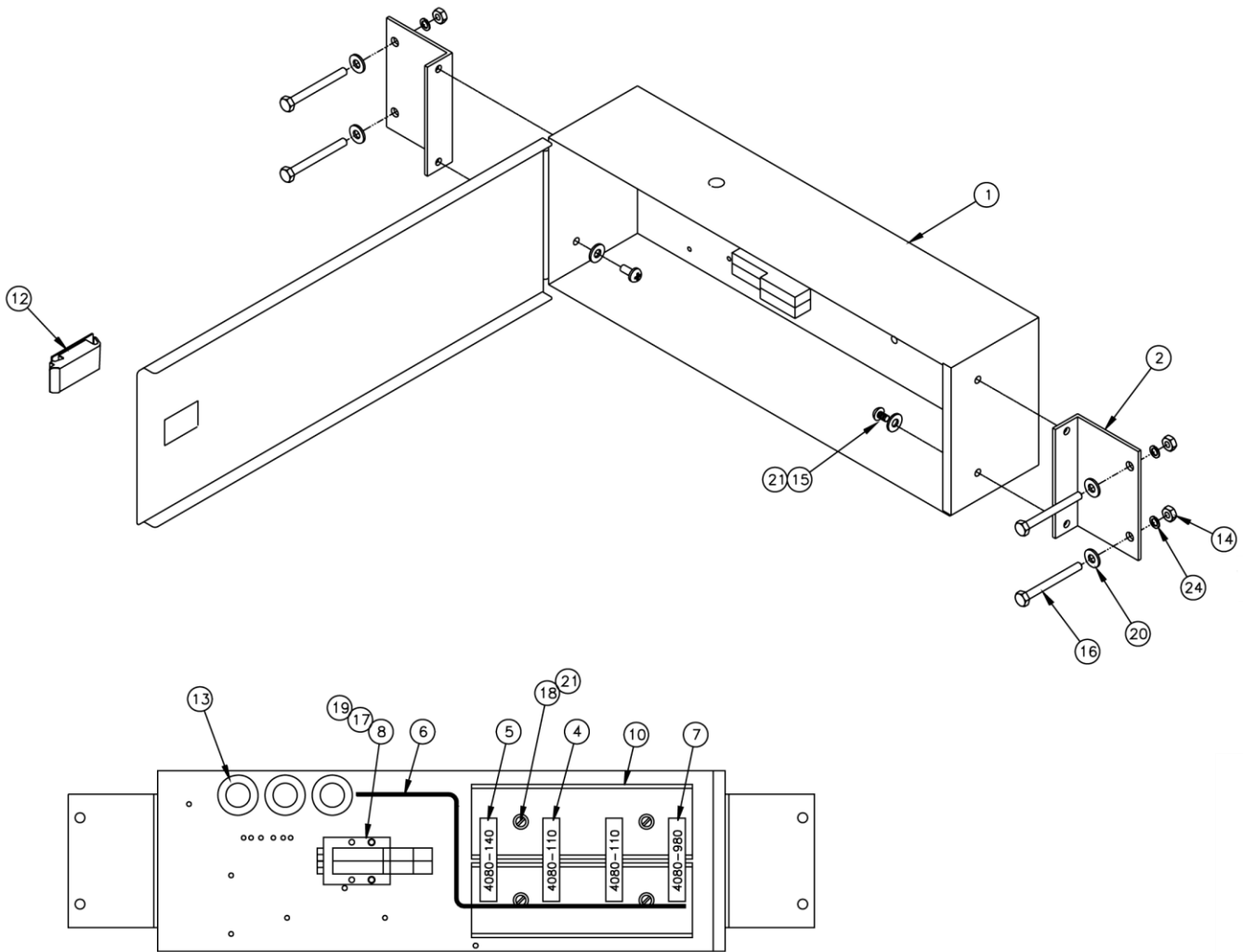

## 1334-3000 Control Panel Assembly

AAC Drawing Number 192539C Rev2

NO.	QTY	PART #	DESCRIPTION	NO.	QTY	PART #	DESCRIPTION
1	1	025-023	Chasis, Ctrl Box	13	3	MM9600K36	Rubber Grommet
2	2	1334-2006	Mount Brkt	14	4	NNK1/4-20	Kep Nut
3	2	4003-MASBUS	Cable	15	4	SSPP98024	Screw, Pan Phillips
4	2	4080-110	Quad In Module	16	4	SSHC01160	Screw, Hex Cap
5	1	4080-140	Quad Out Module	17	2	SSPS90032	Screw, Pan Head
6	1	4080-4129	Cable	18	4	SSPS98024	Screw, Pan Head
7	1	4080-980	Adapter Module	19	2	WWF8	Flat Washer
8	1	AAE211P-2	Solenoid Assy	20	4	WWS1/4	Flat Washer
9	1.5'	EEDC2X2	Wire Duct Cover	21	8	WWFS10	Flat Washer
10	1.5'	EEDF2X2	Wire Duct	22	1	12788-502	Cable
11	2	FFRK44TBS8	Cable	23	1	1334-3000WD1	Wiring Diagram
12	1	MM40450010	Slide Lock Fastener	24	4	WWL1/4	Lock Washer

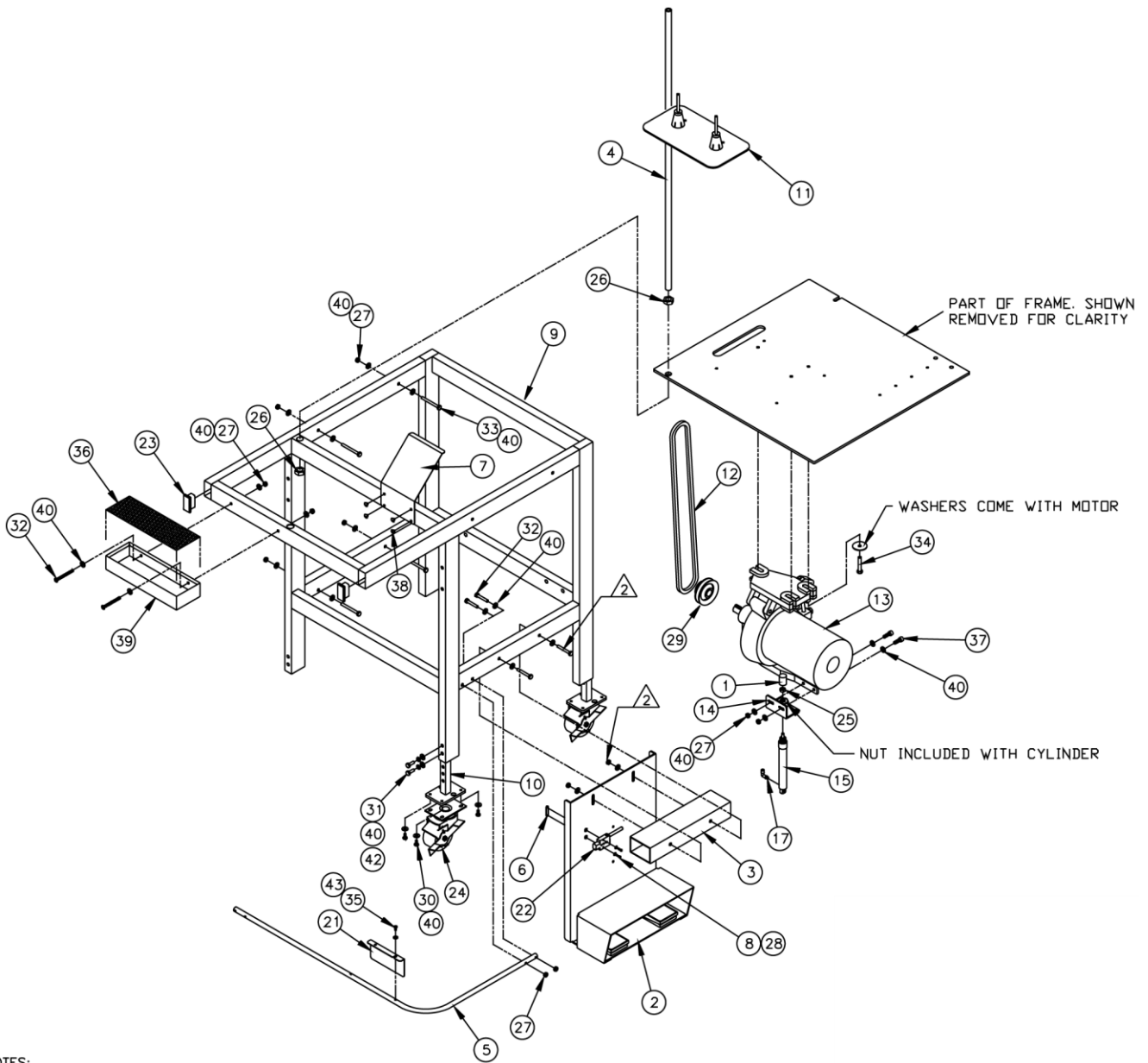

NOTES:

△ NOT SHOWN

△ STRUCTURED ON SUB-ASSY (ITEM 2)

# 1334-2000 Frame Assembly

AAC Drawing Number 192536C Rev9

NO.	QTY	PART #	DESCRIPTION
1	1	11200	Bumper
2	1	132556-011	Foot Pedal Assy
3	1	132556-013	Spacer
4	1	1334-1004	Thread Stand Support
5	1	1334-2008	Slack Guard
6	1	1975-412A	Nut Plate
7	1	1334-2012	Guide
8	2	SSPS70048	Screw, Pan Head
9	1	1334-2100	Frame
10	2	1961-115	Leg Weldment
11	1	1959-112	Thread Plate
12	1	ZX3831	V Belt
13	1	4058-2	Clutch Motor
14	1	97-2602	Cylinder Brkt
15	1	AAC7DP-2	Air Cylinder
16	8	AAF1/8	Plastic Clamp
17	1	AAQME-5-8	Elbow
18	1	FFHBL4570C	Plug
19	25	EE6X750	Cable Tie
20	9'	FF19510	Cable
21	1	1335-2025	Brkt, Loop Photocell
22	1	FFSM312LVQ	Electric Eye
23	2	MM132-1496	End Cap
24	2	MM427-3RB	Caster
25	1	NNJ1/4-28	Jam Nut
26	2	NNJ5/8-18	Jam Nut
27	10	NNK1/4-20	Kep Nut
28	2	WWF4	Flat Washer
29	1	PPM622	Pulley
30	8	SSHC01040	Screw, Hex Cap
31	4	SSHC01048	Screw, Hex Cap
32	4	SSBC01096	Screw, Button Cap
33	4	SSHC01160	Screw, Hex Cap
34	3	SSHC10112	Screw, Hex Cap
35	1	SSHC98024	Screw, Hex Cap
36	1	1335-191	Non-Slip Pad
37	2	SSSC01064	Screw, Socket Cap
38	4	SSTS98016	Screw, Truss Head
39	1	1335-190	Tool Tray
40	30	WWFS1/4	Flat Washer
41	1	FFRK44T3PD	Cable
42	4	WWL1/4	Lock Washer
43	1	WWFS10	Flat Washer

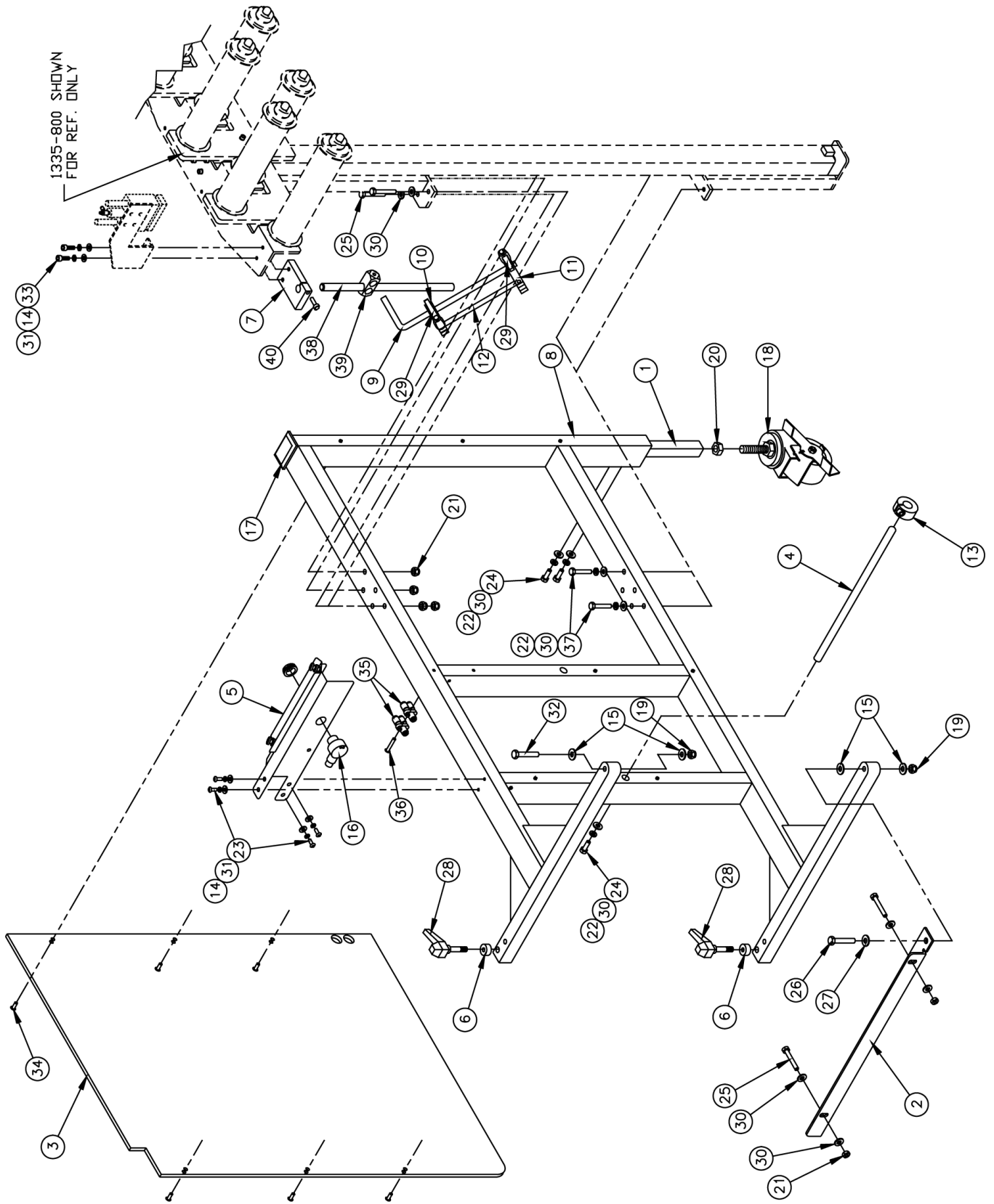

# 1334-2500 Accumulator Frame Assembly

AAC Drawing Number 192537C Rev7

NO.	QTY	PART #	DESCRIPTION
1	1	26127	Leg
2	1	1334-2002	Frame Support
3	1	1334-2003	Cover
4	1	1334-2004	Rod
5	1	1334-2501	Tension Assy
6	2	1334-2007	Spacer
7	1	1334-2011	Guide Rod Mount
8	1	1334-2200	Frame Weldment
9	1	1335-316B	Bent Rod
10	1	1335-318	Rod Slide Arm
11	1	1335-319	Rod Clamp Arm
12	1	1335-320B	Rod
13	2	CCCL8F	Clamp Collar
14	6	WWL10	Lock Washer
15	4	BBTT602	Thrust Washer
16	1	FFT18FF100Q	Eye
17	1	MM132-1496	End Cap
18	1	MM503022LB	Caster
19	2	NNE5/16-18	Elastic Lock Nut
20	1	NNH1/2-13	Hex Nut
21	6	NNK1/4-20	Keq Nut
22	5	WWL1/4	Lock Washer
23	4	SSBC98032	Screw, Button Cap
24	3	SSHC01048	Screw, Hex Cap
25	6	SSHC01112	Screw, Hex Cap
26	1	SSHC10112	Screw, Hex Cap
27	1	WWFS5/16	Flat Washer
28	2	TTH32429	Threaded Handle
29	2	TTH34311	Threaded Handle
30	13	WWFS1/4	Flat Washer
31	6	WWFS10	Flat Washer
32	1	SSHC10128	Screw, Hex Cap
33	2	SSSC98048	Screw, Socket Cap
34	6	SSPP90032	Screw, Pan Phillips
35	2	AAQUY-5-5	Union "Y"
36	1	SSPS90064	Screw, Pan Head
37	2	SSHC01096	Screw, Hex Cap
38	1	8732-0896	Rod, 1/2 x 14
39	1	A-U1	Cross Block
40	1	SSSC98064	Screw, Socket Cap
41	1	4080-4207	Cable
42	1	4080-4208	Cable
43	1	AACR25813R1	Switch
44	1	FFRK44T3PM	Cable

From the library of: Diamond Needle Corp

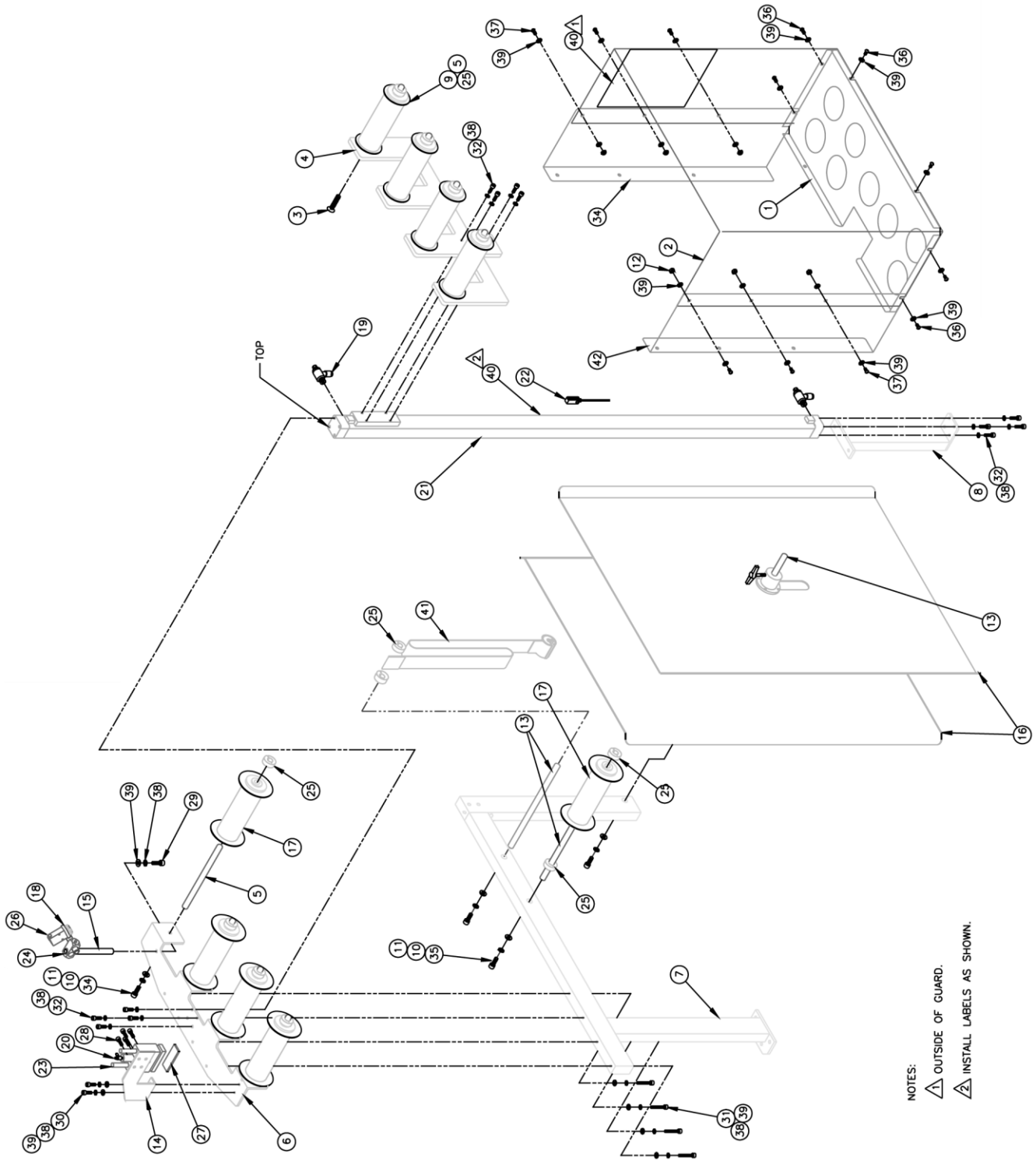

From the library of: Diamond Needle Corp



# 1335Q-800A Accumulator Assembly

AAC Drawing Number 192792C Rev3

NO.	QTY	PART #	DESCRIPTION
1	1	1335-011	Trough Bottom
2	1	1335-012	Guard
3	4	SSFC01056	Screw, Flat Allen
4	1	1335-802	Mnt Plate
5	8	1335-803	Rod
6	1	1335-804A	Mnt Plate
7	1	1335-805B	Mnt Brkt
8	1	1335-809	Mnt Brkt
9	4	1335-814	Roller Assy
10	7	WWL1/4	Lock Washer
11	7	WWFS1/4	Flat Washer
12	6	NNK10-32	Kep Nut
13	3	1335-816	Rod
14	1	1335-824	Brake Mnt
15	1	33025017	Rod
16	2	785-A95-36	Disc
17	5	1335-814A	Roller
18	1	97-1253A	Sensor Brkt
19	2	AA198-2201	Flow Control
20	2	A198RA510	Flow Control
21	1	AACR251117A	Air Cylinder
22	1	AACR25813R	Reed Switch
23	1	AACTE021B	Air Cylinder
24	1	A-U1	Cross Block
25	12	CCCL8F	Clamp Collar
26	1	FFSM312LVQ	Electric Eye
27	3"	MMLSSBB01210	Foam
28	4	SSSC90064	Screw, Socket Cap
29	1	SSSC95040	Screw, Socket Cap
30	2	SSSC98040	Screw, Socket Cap
31	4	SSSC98144	Screw, Socket Cap
32	12	SSSCM5X16	Screw, Socket Cap
33	2	SSSC01064	Screw, Socket Cap
34	1	1335-012E	Accumulator Mount, Right
35	2	SSSC01032	Screw, Socket Cap
36	6	SSBC98024	Screw, Button Cap
37	6	SSBC98040	Screw, Button Cap
38	19	WWL10	Lock Washer
39	25	WWFS10	Flat Washer
40	1	1335-LAB1	Label
41	1	1335-825	Tension Strap
42	1	1335-012D	Accumulator Mount, Left

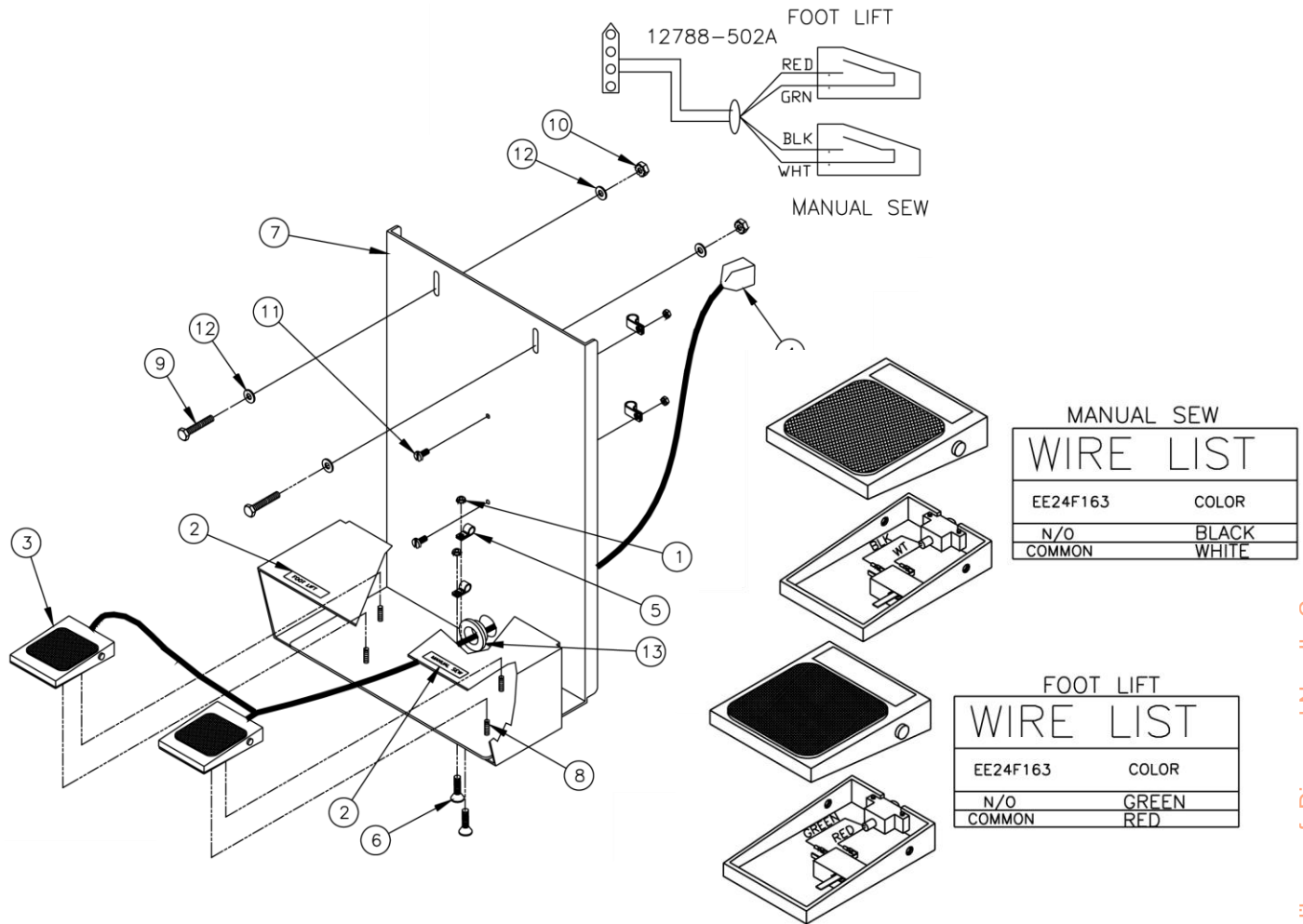

## 132556-011 Dual Foot Pedal Assembly

AAC Drawing Number 125506B Rev3

NO.	QTY	PART #	DESCRIPTION
1	4	NNK6-32	Kep Nut
2	1	132556-012L	Label
3	2	1278-6161	Foot Switch Mod.
4	1	12788-502A	Cable Assy
5	4	AAF3/16	Plastic Clamp
6	2	SSFC80024	Screw, Flat Allen
7	1	132556-010	Foot Pedal Plate
8	4	SSFC80016	Screw, Flat Allen
9	2	SSHC01096	Screw, Hex Cap
10	2	NNK1/4-20	Kep Nut
11	2	SSPS80024	Screw, Pan Head
12	4	WWFS1/4	Flat Washer
13	1	MM9600K36	Rubber Grommet

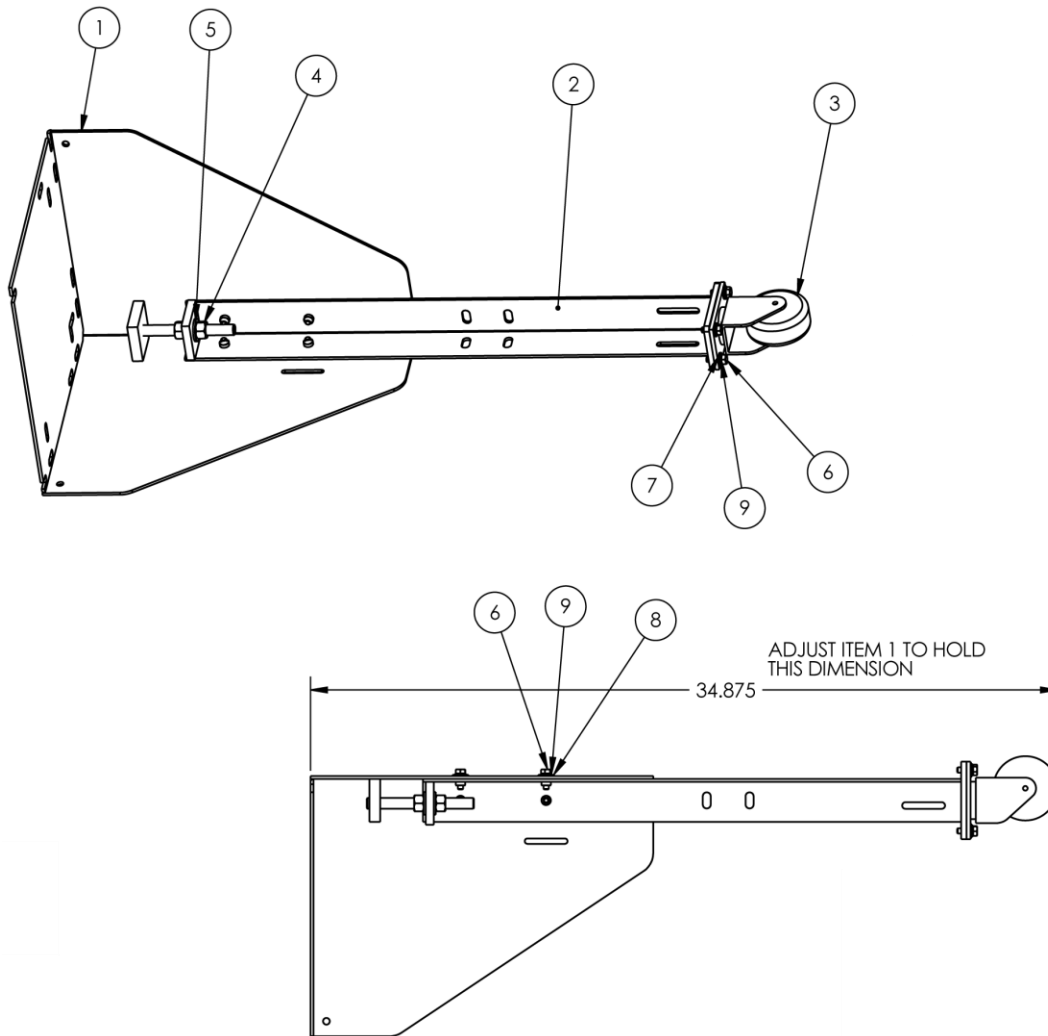

From the library of: Diamond Needle Corp

## 1335050 Leg Assembly

AAC Drawing Number 1335050 Rev2

NO.	QTY	PART #	DESCRIPTION
1	1	1335110	MOUNTING ASSEMBLY WELDMENT
2	1	1335120	LEG ASSEMBLY WELDMENT
3	1	MM427-3RB	CASTER, SWIVEL, 3" RUBBER
4	2	NNH1/2-13	1/2-13 HEX NUT
5	8	SSHC01048	1/4-20 X 3/4 HEX HEAD
6	4	WWF1/4	WASHER, FLAT, 1/4", COM
7	6	WWFS1/4	WASHER FLAT, 1/4
8	8	WWL1/4	1/4 LW

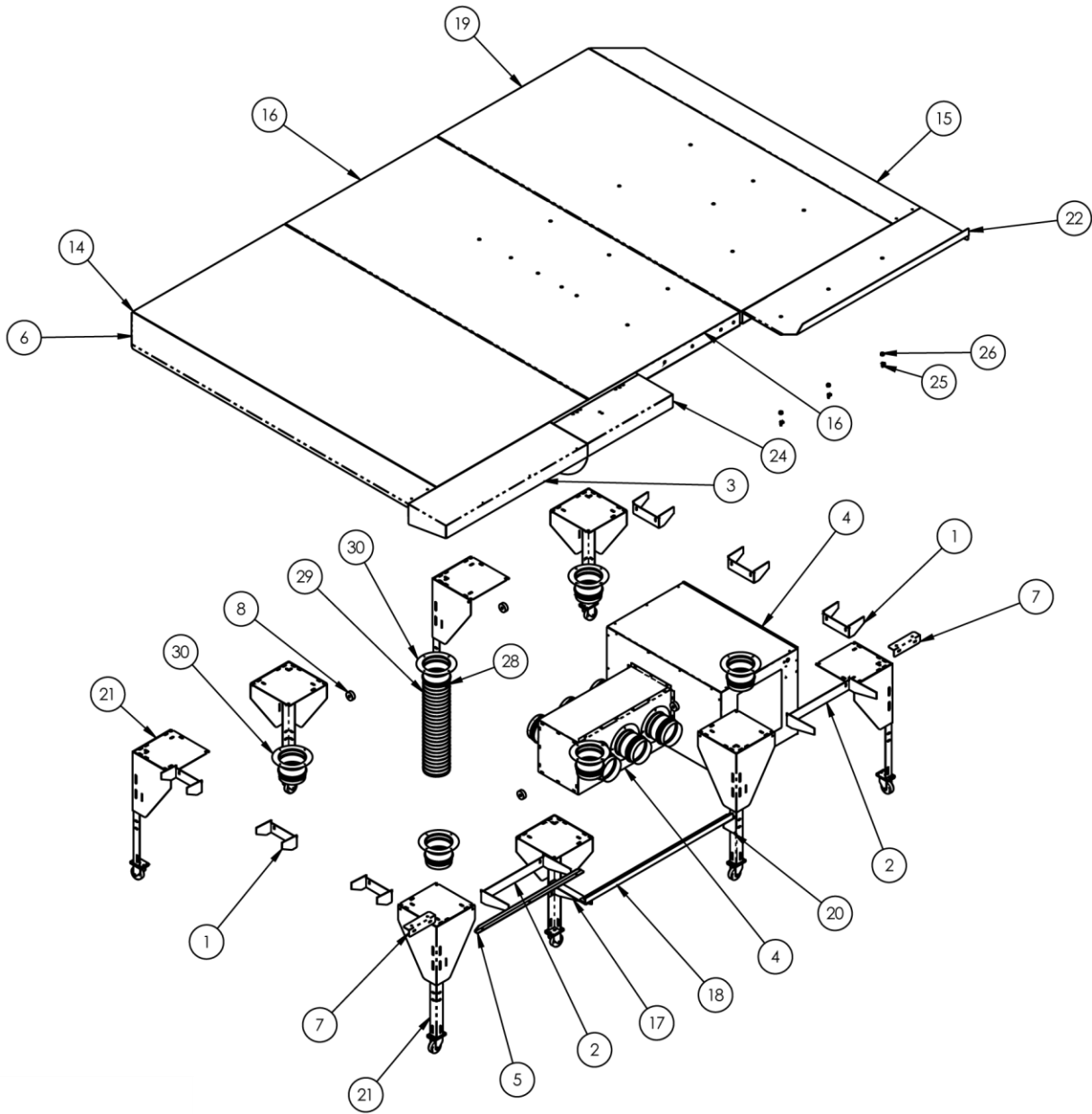

# 1335000 Air Table Assembly

AAC Drawing Number 1335000 Rev3

NO.	QTY	PART #	DESCRIPTION
1	6	1335-0168B	SHELF SUPPORT
2	2	1335-0168C	SHELF SUPPORT
3	1	1335-0172A	EXTENSION, TABLE, 9"
4	1	1335-0190	BLOWER BOX ASSY
5	1	1335-172	EDGE GUIDE
6	1	1335-175A	EXTENSION, TABLE
7	2	1335-179	ANGLE,SHELF
8	4	1335-180	SPACER, AIR TABLE
NS	AR	1335000INS1	INSTRUCTIONAL,PARTS LIST
NS	AR	1335000INS2	INSTRUCTIONAL,PARTS LIST
NS	AR	1335000INS3	INSTRUCTIONAL,LEFT TABLE ASSY
NS	AR	1335000INS4	INSTRUCTIONAL,RIGHT TABLE ASSY
NS	AR	1335000INS5	INSTRUCTIONAL,AIR TABLE
14	1	1335020	AIR TABLE, LEFT
15	1	1335029	SHELF, LONG RIGHT,9" EXT
16	1	1335030	AIR TABLE ASSY,CENTER
17	1	1335031	LATCH BRACKET
18	1	1335032	AIR LOCK STRIKE
19	1	1335040	AIR TABLE ASSY,RIGHT
20	1	1335042	LATCH BRACKET
21	8	1335050	LEG ASSEMBLY
22	1	1335065	EXTENSION, TABLE, 12"
NS	1	1335075	HARDWARE PACKAGE
24	1	1335130	TRAP DOOR ASSEMBLY
25	3	AA198RA510	FLOW CONTROL,5/32X10-32
26	3	AAFJ11	SOFFIE JET & NUT ONLY
27	2	CCCL8F	CLAMP COLLAR- 1/2
28	12	MM5415K39	CLAMP,HOSE,WORM TYPE
29	40FT*	MM5501K35	FLEX AIR DUCT,6" ID
30	6	MMATT06	TAKE OFF,6"

From the library of: Diamond Needle Corp

# 1335000INS1

AAC Drawing Number 1335000INS1 Rev0

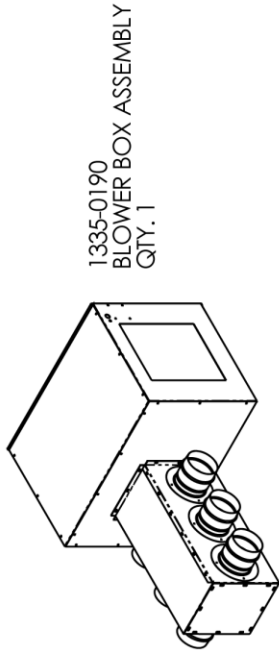

1335020  
AIR TABLE ASSEMBLY, LEFT  
QTY. 1

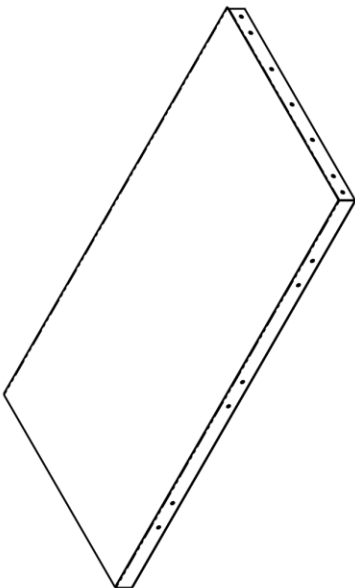

1335030  
AIR TABLE ASSEMBLY, CENTER  
QTY. 1

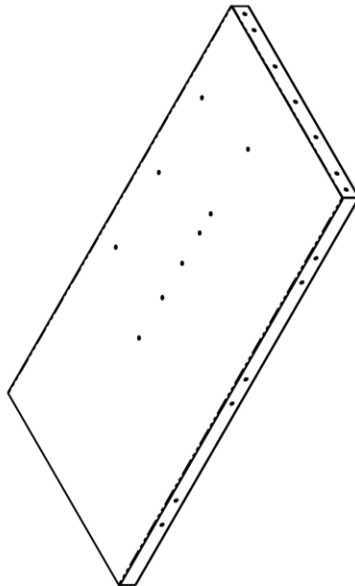



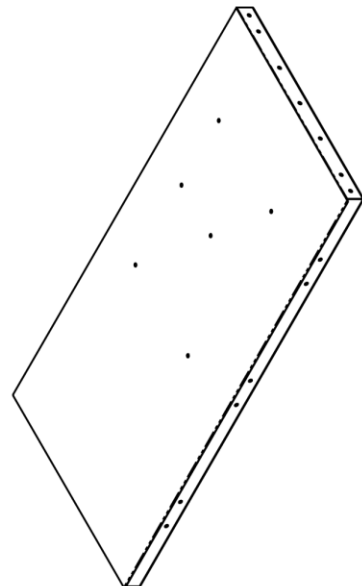





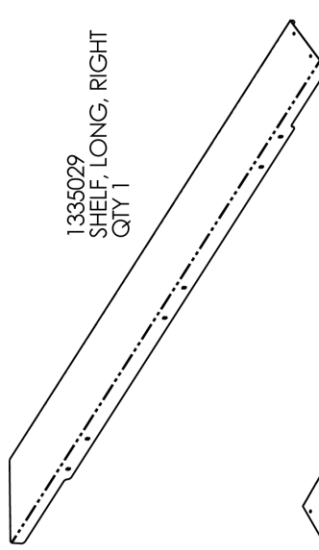

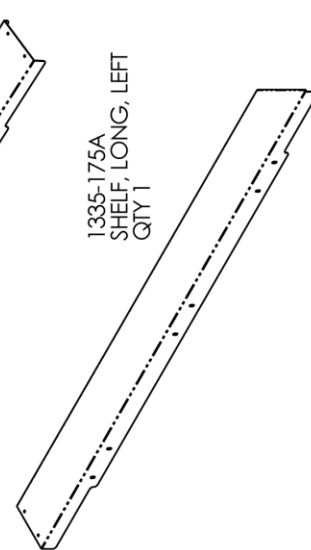

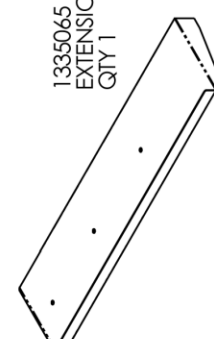
1335040  
AIR TABLE ASSEMBLY, RIGHT  
QTY. 1

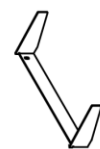
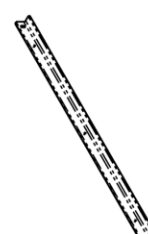

# 1335000INS2

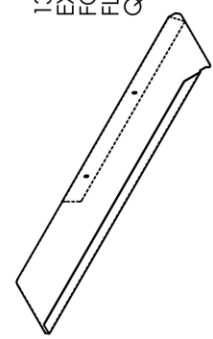
AAC Drawing Number 1335000INS2 Rev2

<p>1335029 SHELF, LONG, RIGHT QTY 1</p> 	<p>1335-179 SHELF SUPPORT ANGLE QTY 2 (AUTOMATIC) QTY 1 (SEMI-AUTOMATIC)</p> 	<p>AAFJ11 SOFFIE JET QTY 3 (SEMI-AUTO ONLY)</p> 
<p>1335-175A SHELF, LONG, LEFT QTY 1</p> 	<p>1335042 SUPPORT, AIR LOCK STRIKE, SHORT QTY 1</p> 	<p>AA198RA510 FLOW CONTROL QTY 3 (SEMI-AUTO ONLY)</p> 
<p>1335065 EXTENSION, REAR QTY 1</p> 	<p>1335-172 EDGE GUIDE QTY 1 AUTOMATIC UNIT ONLY</p> 	<p>MMATT06 TAKE OFF FLANGE QTY 6</p> 
<p>1335-0168C EXTENSION SUPPORT QTY 2 (AUTOMATIC) QTY 1 (SEMI-AUTOMATIC)</p> 	<p>1335032 AIR LOCK STRIKE, CONSOLE QTY 1</p> 	<p>MM5501K35 FLEX AIR DUCT 2 X 5' 2 X 6' 2 X 10' TOTAL = 42'</p> 
<p>1335-0168B SHELF SUPPORT QTY 6</p> 	<p>1335031 SUPPORT, AIR LOCK STRIKE, LONG QTY 1</p> 	<p>MM5415K39 HOSE CLAMP QTY 12</p> 
<p>1317281 EXTENSION, REAR FOR USE WITH 1317 FLANGER CONSOLES ONLY QTY 1</p> 	<p>1335075 HARDWARE BAG QTY 1</p> 	

From the library of: Diamond Needle Corp

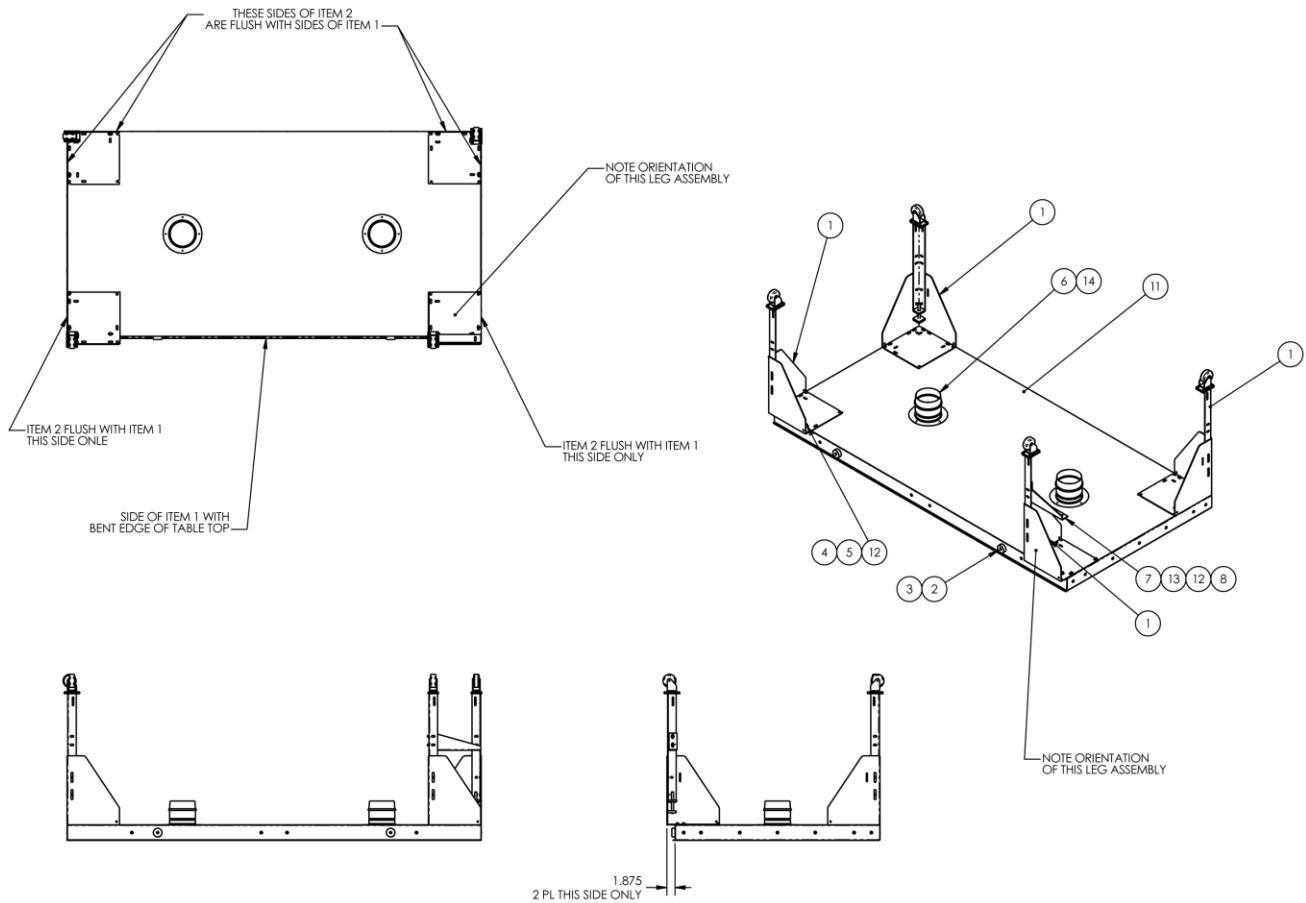

## 1335000INS3 Left Air Table Assembly

AAC Drawing Number 1335000INS3 Rev1

NO.	QTY	PART #	DESCRIPTION
1	4	1335050	LEG ASSEMBLY
2	2	1335-180	SPACER, AIR TABLE
3	2	SSSC10064	5/16-18 X 1" LG SHCS
4	20	WWFS1/4	1/4 FW
5	16	WWL1/4	1/4 LW
6	2	MMATT06	TAKE OFF, 6"
7	1	1335031	LATCH BRACKET
8	2	NNH5/16-18	5/16-18 HEX NUT
9	2	WWL5/16	5/16 LW
10	8	SSZS93032	SCREW, SHEET METAL
11	1	1335020	AIR TABLE, LEFT
12	17	SSHC01048	1/4-20 X 3/4 HEX HEAD
13	1	SSHC05048	1/4-28 X 3/4 HEX HEAD



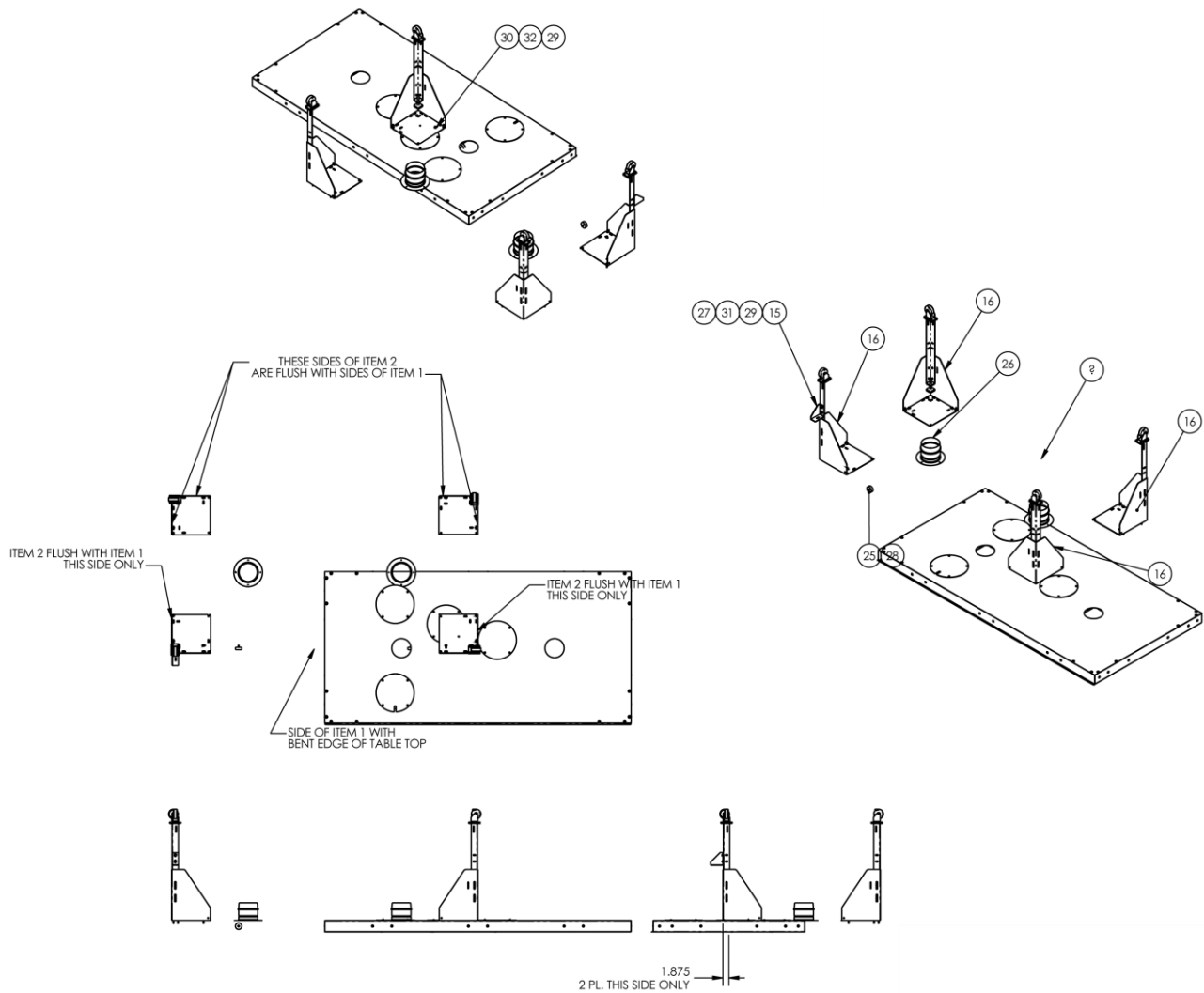

From the library of: Diamond Needle Corp

## 1335000INS4 Right Air Table Assembly

AAC Drawing Number 1335000INS4 Rev2

NO.	QTY	PART #	DESCRIPTION
1	1	1335042	LATCH BRACKET
2	4	1335050	LEG ASSEMBLY
3	2	1335-180	SPACER, AIR TABLE
4	2	MMATT06	TAKE OFF, 6"
5	2	NNH1/4-20	1/4-20 HEX NUT
6	2	SSSC10064	5/16-18 X 1" LG SHCS
7	16	WWFS1/4	1/4 FW
8	4	WWFS5/16	5/16" FW
9	16	WWL1/4	1/4 LW
10	1	1335040	AIR TABLE ASSY, RIGHT
11	18	SSHC01192	1/4-20 X 3 HEX HEAD

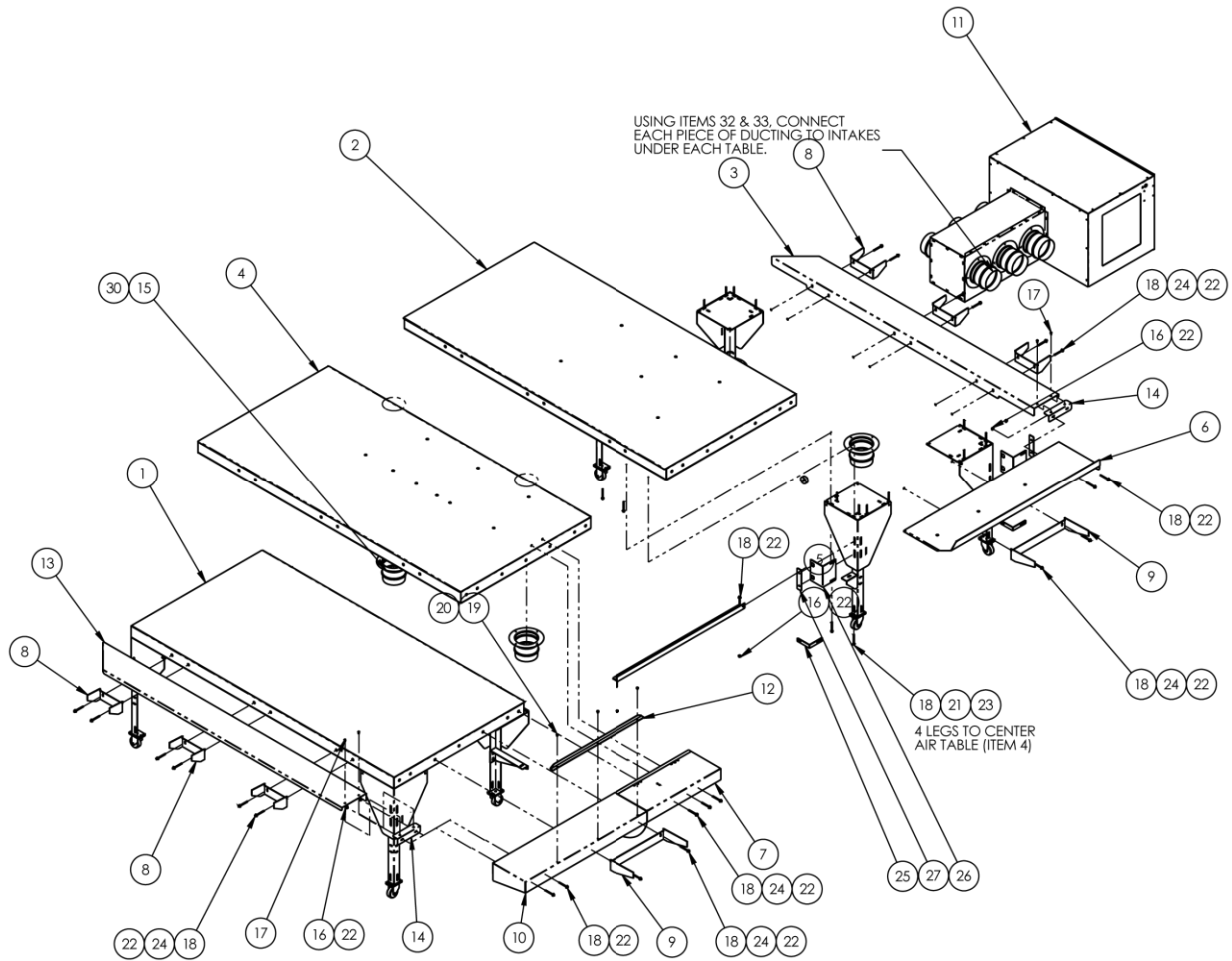

From the library of: Diamond Needle Corp

## 1335000INS5 Air Table Assembly

AAC Drawing Number 1335000INS5 Rev2

NO.	QTY	PART #	DESCRIPTION	NO.	QTY	PART #	DESCRIPTION
1	1	1335000INS3	LEFT AIR TABLE SUB-ASSY	15	2	MMATT06	TAKE OFF,6"
2	1	1335000INS4	RIGHT AIR TABLE SUB-ASSY	16	6	NNH1/4-20	1/4-20 HEX NUT
3	1	1335029	SHELF, LONG RIGHT, 9" EXT	17	4	SSBC01032	1/4-20 X 1/2 LG. BUTHCS
4	1	1335030	AIR TABLE ASSY, CENTER	18	33	SSHCO1192	1/4-20 X 3 HEX HEAD
5	1	1335032	AIR LOCK STRIKE	19	3	SSSC95024	#10-24 X 3/8 LG. SHCS
6	1	1335065	EXTENSION, TABLE, 12"	20	3	WWFS10	#10 FW
7	1	1335130	TRAP DOOR ASSEMBLY	21	8	WWFS1/4	1/4 FW
8	6	1335-0168B	SHELF SUPPORT	22	31	WWFS5/16	5/16" FW
9	2	1335-0168C	SHELF SUPPORT	23	8	WWL1/4	1/4 LW
10	1	1335-0172A	EXTENSION, TABLE, 9"	24	19	WWL5/16	5/16 LW
11	1	1335-0190	BLOWER BOX ASSY	25	2	1335073	BRACKET, LOWER LEG
12	1	1335-172	EDGE GUIDE	30	24	SSZS93032	SCREW, SHEET METAL
13	1	1335-175A	EXTENSION, TABLE	26	2	1335074	PLATE, MOUNTING
14	2	1335-179	ANGLE, SHELF	27	2	1335093	Plate, washer

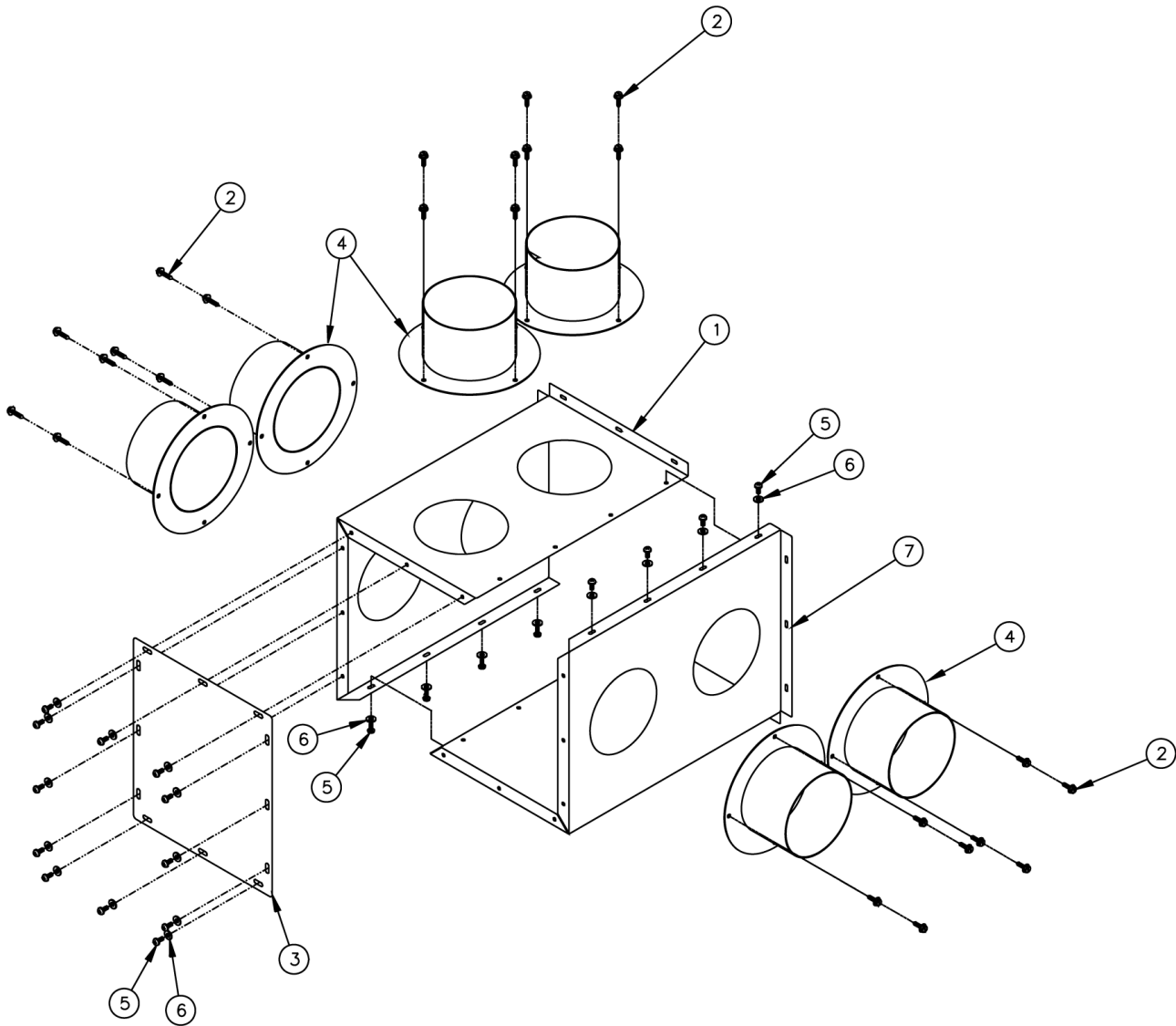

From the library of: Diamond Needle Corp

## 1335-0167 Duct Assembly

AAC Drawing Number 297095C Rev4

NO.	QTY	PART #	DESCRIPTION
1	1	1335-0198	Duct Half
2	24	SSZS93032	Screw, Sheet Metal
3	1	1335-0199	Duct End
4	6	MMATT06	Take Off
5	20	SSPS90024	Screw, Pan Phillips
6	20	WWF8	Flat Washer
7	1	1335-0198A	Duct Half

# 1335-905 Stepper Box Adjustments

AP-28-601E (LOGIC BOARD)

PULLER JOG SPEED (NOT USED)

AP-28-600C

ATLANTA ATTACHMENT COMPANY  
401 INDUSTRIAL PARK DR., LAWRENCEVILLE, GA. 30245  
770-963-7569

PULLER

AP-28-601Y (LOGIC BOARD)

NO ADJUSTMENTS INSIDE

AP-28-600GG

ATLANTA ATTACHMENT COMPANY  
401 INDUSTRIAL PARK DR., LAWRENCEVILLE, GA. 30245  
770-963-7569

ROTATOR

AP-28-601GG (LOGIC BOARD)

CONV. JOG SPEED (NOT USED)

AP-28-600GG

ATLANTA ATTACHMENT COMPANY  
401 INDUSTRIAL PARK DR., LAWRENCEVILLE, GA. 30245  
770-963-7569

CONVEYOR / EDGE GUIDE

AP-28-802F

ATLANTA ATTACHMENT COMPANY  
401 INDUSTRIAL PARK DR., LAWRENCEVILLE, GA. 30245  
770-963-7569

PULLER

AP-28-800Y

ATLANTA ATTACHMENT COMPANY  
401 INDUSTRIAL PARK DR., LAWRENCEVILLE, GA. 30245  
770-963-7569

ROTATOR

AP-28-602D

ATLANTA ATTACHMENT COMPANY  
401 INDUSTRIAL PARK DR., LAWRENCEVILLE, GA. 30245  
770-963-7569

CONVERTER DRIVER (TOP BOARD)

AP-28-602D

ATLANTA ATTACHMENT COMPANY  
401 INDUSTRIAL PARK DR., LAWRENCEVILLE, GA. 30245  
770-963-7569

EDGE GUIDE DRIVER (BOTTOM BOARD)

AP-28-802F

ATLANTA ATTACHMENT COMPANY  
401 INDUSTRIAL PARK DR., LAWRENCEVILLE, GA. 30245  
770-963-7569

PULLER

AP-28-800Y

ATLANTA ATTACHMENT COMPANY  
401 INDUSTRIAL PARK DR., LAWRENCEVILLE, GA. 30245  
770-963-7569

ROTATOR

AP-28-802D

ATLANTA ATTACHMENT COMPANY  
401 INDUSTRIAL PARK DR., LAWRENCEVILLE, GA. 30245  
770-963-7569

CONVERTER DRIVER (TOP BOARD)

AP-28-802D

ATLANTA ATTACHMENT COMPANY  
401 INDUSTRIAL PARK DR., LAWRENCEVILLE, GA. 30245  
770-963-7569

EDGE GUIDE DRIVER (BOTTOM BOARD)

THUMB WHEELS ADJUST THE SPEED OF THE PULLER WHILE SEWING. THIS IS PROPORTIONAL TO STITCH LENGTH. SET THIS BOX "420".

THUMB WHEELS ADJUST THE TURNING SPEED OF THE ROTATOR WHILE PLEATING. THIS IS PROPORTIONAL TO PLEAT SIZE. SET TO "950".

THUMB WHEELS ADJUST THE SPEED OF THE CONVEYOR WHILE SEWING. THIS IS PROPORTIONAL TO STITCH LENGTH. THIS MAKES THE CONV 12% FASTER THAN THE PULLER.

SW #1 CLOSED FOR YAMATO PULLER FOR SINGER CONVECTOR ALL OTHERS OPEN

ALL SW'S OPEN

ROTATOR JOG SPEED WHEN RETURNING TO HOME POSITION SET TO "54"

NO.	REVISION	DATE	DR.	CHK.	QTY.	ITEM	RECD. NO.	DESCRIPTION	PART NO.	STOCK SIZE
2	202-02	10-3	JT			10-3		DEFAULTS		
1	239-01	10-9	DW	JT		10-9		DEFAULTS		

  

PLAN	2nd DES. 1335
BURR BENCH	
DRY CLEAN	
HEAD	
SAND BLAST	
BUFF	
PARTS CLEAN	
CHARMATE	
TIME SAVE	
OIL	

NAME		ATLANTA ATTACHMENT COMPANY
ASSEMBLY		1335
DES. BY		P. DASHER
DR. BY		MATT DASHER
CHK. BY		JEFF THOMAS
DRAWING NO.		261346C
PART NO.		1335-905
REV.		2

194-01

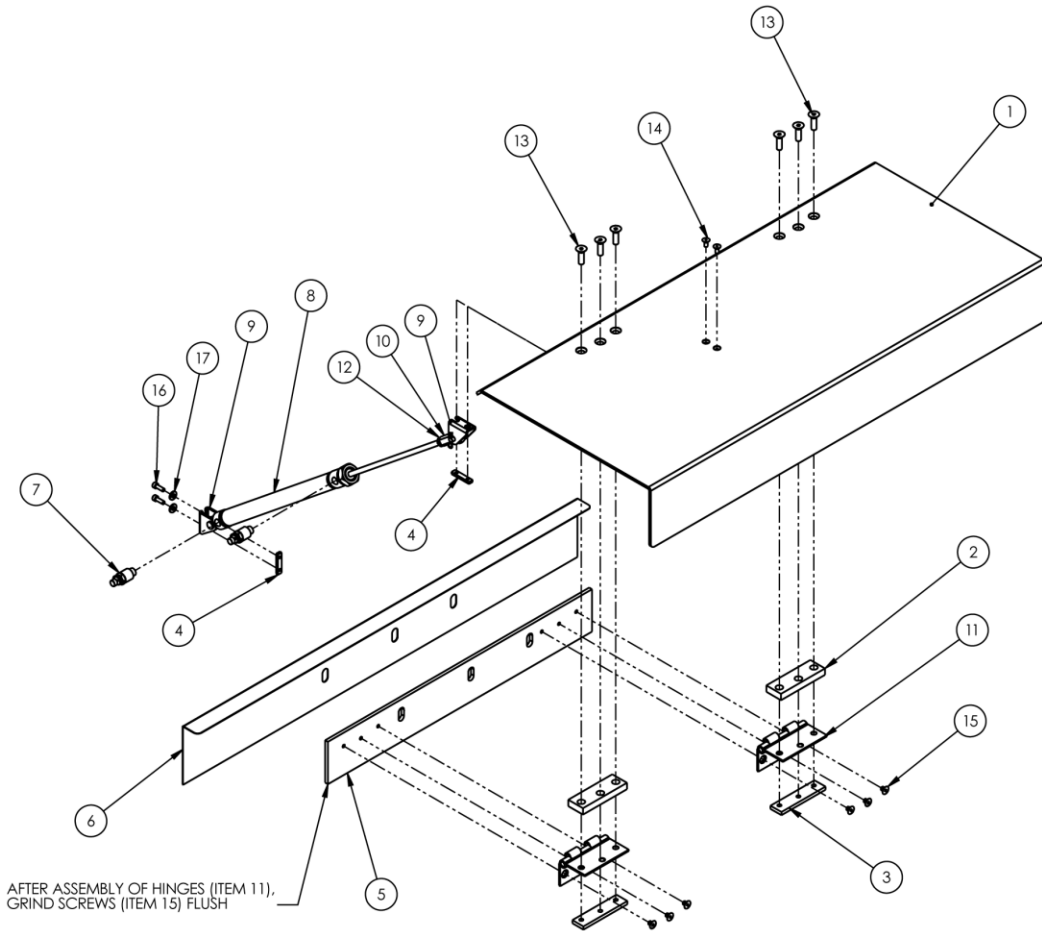

## 1335130 Trap Door Assembly

AAC Drawing Number 1335130 Rev2

NO.	QTY	PART #	DESCRIPTION
1	1	1335-143	TRAP DOOR
2	2	1335-146	WASHER PLATE
3	2	1335-149	PLATE,NUT 1/4-20 3 PL
4	2	1335-149A	PLATE,NUT,8-32@.75 CTC
5	1	1335039	HINGE MOUNTING
6	1	1335043	SHIELD
7	2	AA198RA508	FLOW CONTROL,5/32 X 1/8"
8	2	AAFBP-11C	BRKT,PIVOT,1/4 BORE
9	1	BBAW-4	BEARING,ROD END,FEMALE
10	2	MM741-3A	HINGE,3 X 3,STANLEY
11	1	NNJ1/4-28	1/4-28 HEX JAM NUT
12	6	SSFC01056	1/4-20 X 7/8 FLAT ALLEN
13	2	SSFC90024	#8-32 x 3/8 FLAT ALLEN
14	6	SSFC98016	#10-32 X 1/4 FLAT ALLEN
15	2	SSSC90032	#8-32 X 1/2 Lg. SHCS
16	2	WWF8	WASHER, FLAT #8

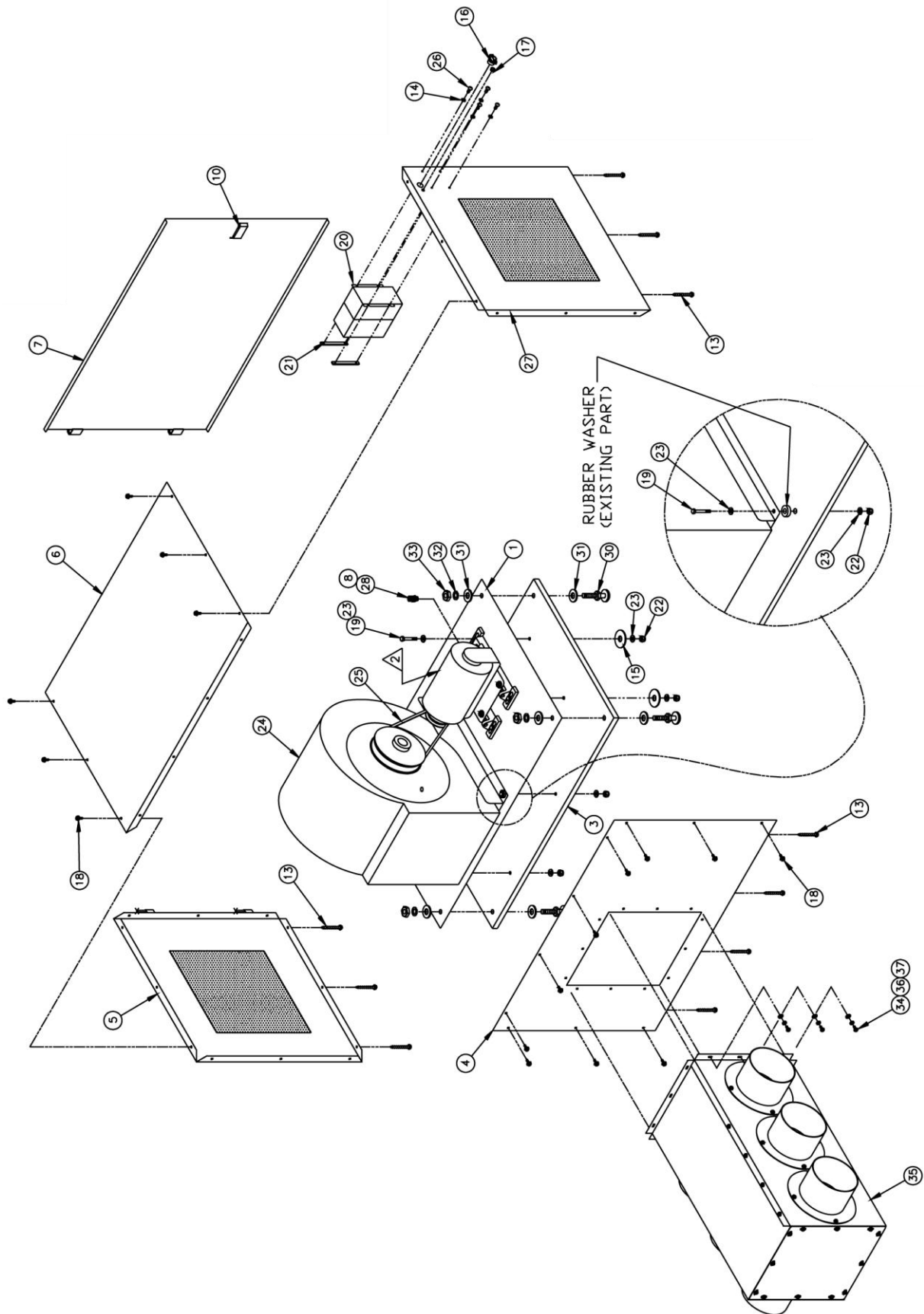

# 1335-0190 Blower Box Assembly

AAC Drawing Number 297096C Rev11

NO.	QTY	PART #	DESCRIPTION
1	1	1335-0187	Base Plate
2	1	1335-0190WD	Wiring Diagram
3	1	1335-0189	Box Base
4	1	1335-0191	Rear Panel
5	1	1335-0192	Right Side Panel
6	1	1335-0193	Top Panel
7	1	1335-0194	Door Panel
8	1	MM655445	Conduit Locknut
9	1.3'	EE16-4	Cable
10	1	MM40450010	Slide Lock
11	1	FF274-226	Connector
12	2'	FF1216	Cable
13	10	SSZH#10048	Screw, Sheet Metal
14	4	WWSI10	Internal Tooth Washer
15	4	WWFE020	Fender Washer
16	1	K-235	Romex Connector
17	1	EESB-375-4	Heyco Bushing
18	16	SSZH#10032	Screw, Sheet Metal
19	8	SSHC10128	Screw, Hex Cap
20	1	MMLZF092A	Drive
21	2	1335-903	Nut Plate
22	8	NNE5/16-18	Elastic Lock Nut
23	16	WWFS5/16	Flat Washer
24	1	MM7D634	Blower
25	1	ZX5036	V Belt
26	4	SSBC90032	Screw, Button Cap
27	1	1335-0192A	Left Side Panel
28	1	EEC403083	Connector
29	1	FF274-224	Connector
30	4	MMFB4444	Rubber Foot
31	4	WWL1/2	Lock Washer
32	8	WWF1/2	Flat Washer
33	4	NNH1/2-13	Hex Nut
34	12	SSPS90024	Screw, Pan Head
35	1	1335099	Duct Assy
36	12	WWF8	Flat Washer
37	12	WWL8	Lock Washer
38	AR	K-CB600	Motor Starter

From the library of: Diamond Needle Corp

# 1334-PD1 Pneumatic Diagram

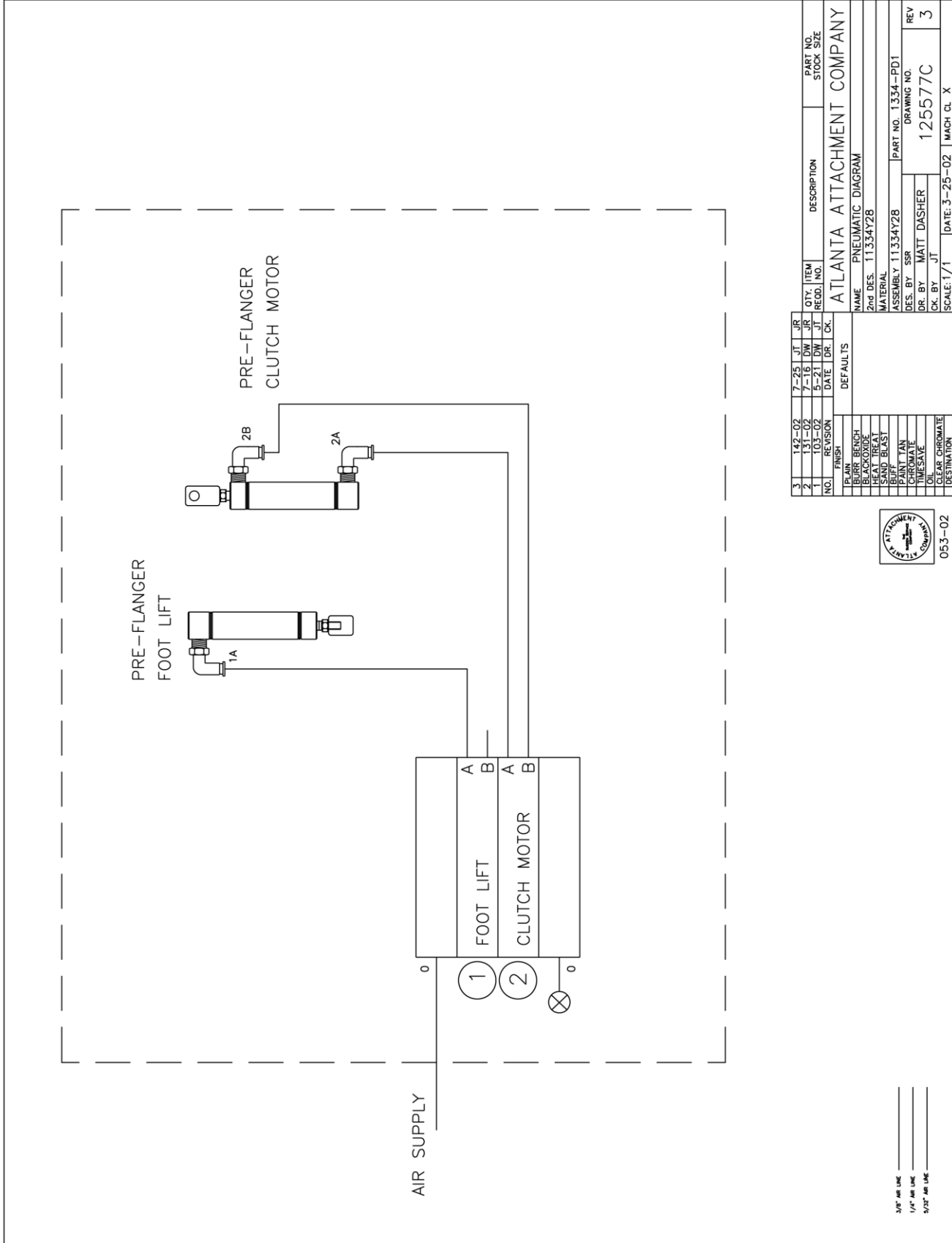

3/16" AIR LINE  
1/4" AIR LINE  
5/32" AIR LINE



053-02

NO.	REVISON	DATE	DR.	CK.	DEFULTS
3	142-02	7-25	JT	JR	
2	133-02	7-25	JT	JR	
1	103-02	5-23	DM	JT	
1	103-02	5-23	DM	JT	

QTY.	ITEM	DESCRIPTION	PART NO.	STOR. SIZE
		ATLANTA ATTACHMENT COMPANY		
		PNEUMATIC DIAGRAM		
		2nd DES. 11334Y28		
		ASSEMBLY 11334Y28	PART NO. 1334-PD1	
		DES. BY SSR	DRAWING NO.	REV
		DR. BY MATT DASHER	125577C	3
		CK. BY JT		
		SCALE: 1/1	DATE: 3-25-02	MACH. CL. X

FINISH	DESTINATION
PLAIN	
BURR BENCH	
BLACK OXIDE	
BEAN OIL	
SAND BLAST	
BLUFF	
PAINT TAN	
PHOSPHATE	
TIME SAVE	
OIL	
GEAR CHROMATE	



# 1335Q-PD2 Pneumatic Diagram

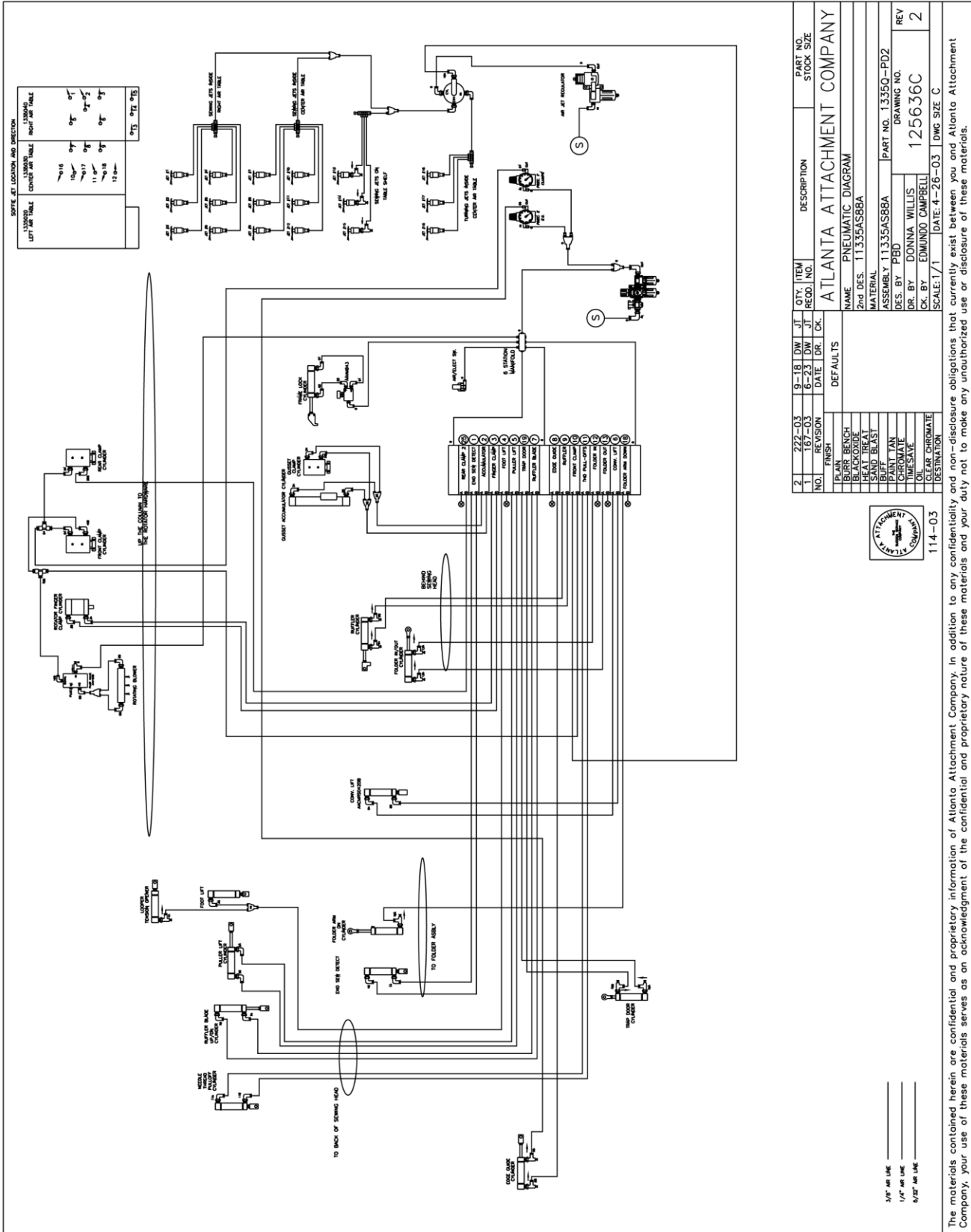

From the library of: Diamond Needle Corp

# 1334-3000WD1 Wiring Diagram

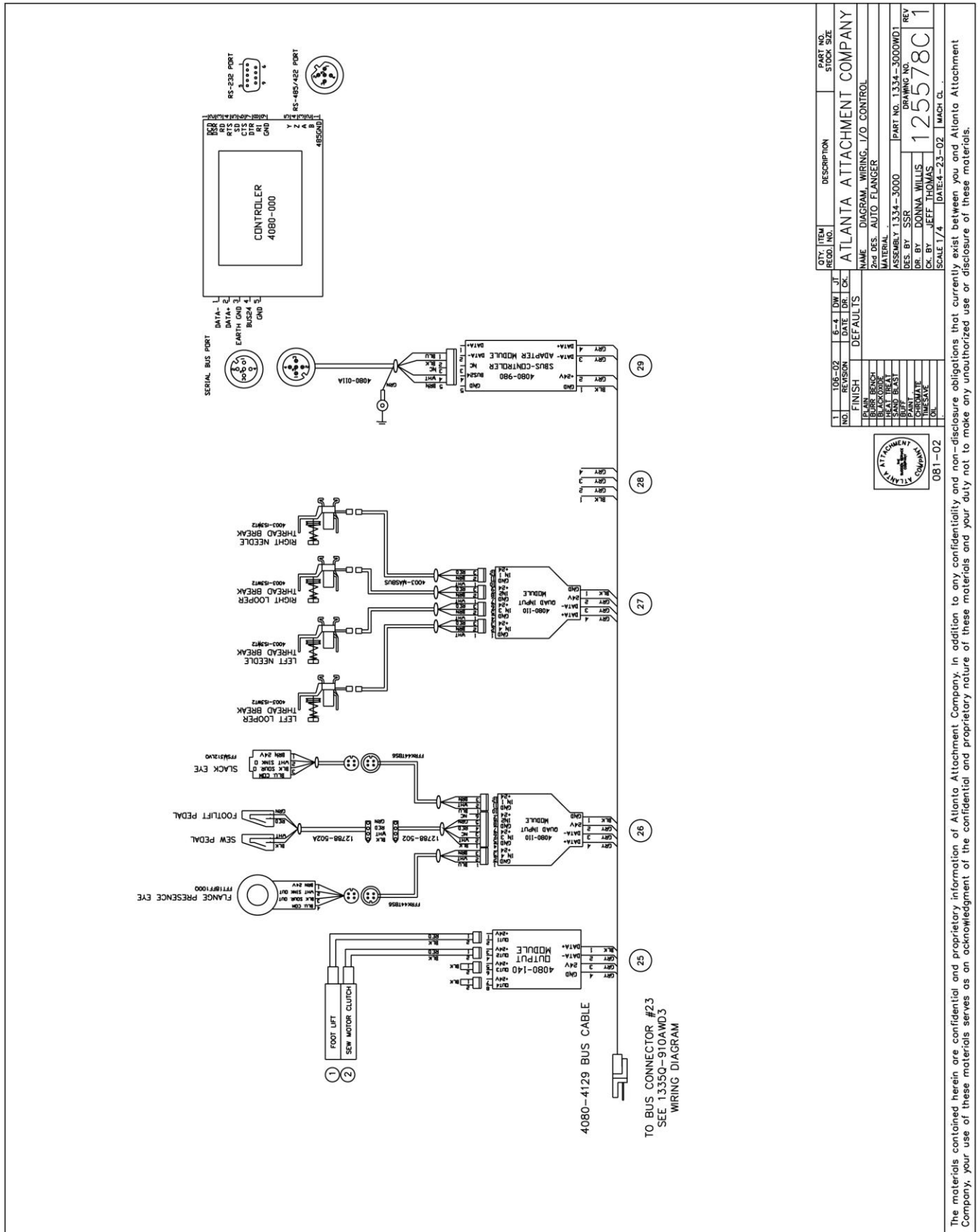

TO BUS CONNECTOR #23  
SEE 1335Q-910AWD3  
WIRING DIAGRAM

QTY.	ITEM	DESCRIPTION	PART NO.	STOCK SIZE
1	4080-4129	4080-4129 BUS CABLE		
1	4080-140	4080-140 OUTPUT MODULE		
1	4080-110	4080-110 QUAD INPUT MODULE		
1	4080-980	4080-980 SUBS-CONTROLLER NC		
1	4080-011A	4080-011A SERIAL BUS PORT		
1	4080-000	4080-000 CONTROLLER		

NO.	REV.	DATE	BY	CHK.	DESCRIPTION
1	1				DEFAULTS

FINISH		DESCRIPTION		PART NO.	
PLN	PLN	ATLANTA ATTACHMENT COMPANY	ATLANTA ATTACHMENT COMPANY	1334-3000WD1	1334-3000WD1
DRG	DRG	DIAGRAM, WIRING, I/O CONTROL	DIAGRAM, WIRING, I/O CONTROL	125578C	125578C
MTRL	MTRL	MATERIAL	MATERIAL		
ASSEMBLY	ASSEMBLY	ASSEMBLY 1334-3000	ASSEMBLY 1334-3000		
DES. BY	DES. BY	SSR	SSR		
DR. BY	DR. BY	DONNA WILLIS	DONNA WILLIS		
CHK. BY	CHK. BY	JEFF THOMAS	JEFF THOMAS		
SCALE	SCALE	1/4	1/4		
DATE	DATE	4-23-02	4-23-02		
MACH. CL.	MACH. CL.				



The materials contained herein are confidential and proprietary information of Atlanta Attachment Company. In addition to any confidentiality and non-disclosure obligations that currently exist between you and Atlanta Attachment Company, your use of these materials serves as an acknowledgment of the confidential and proprietary nature of these materials and your duty not to make any unauthorized use or disclosure of these materials.

From the library of: Diamond Needle Corp

# 1335-900AWD1 Wiring Diagram

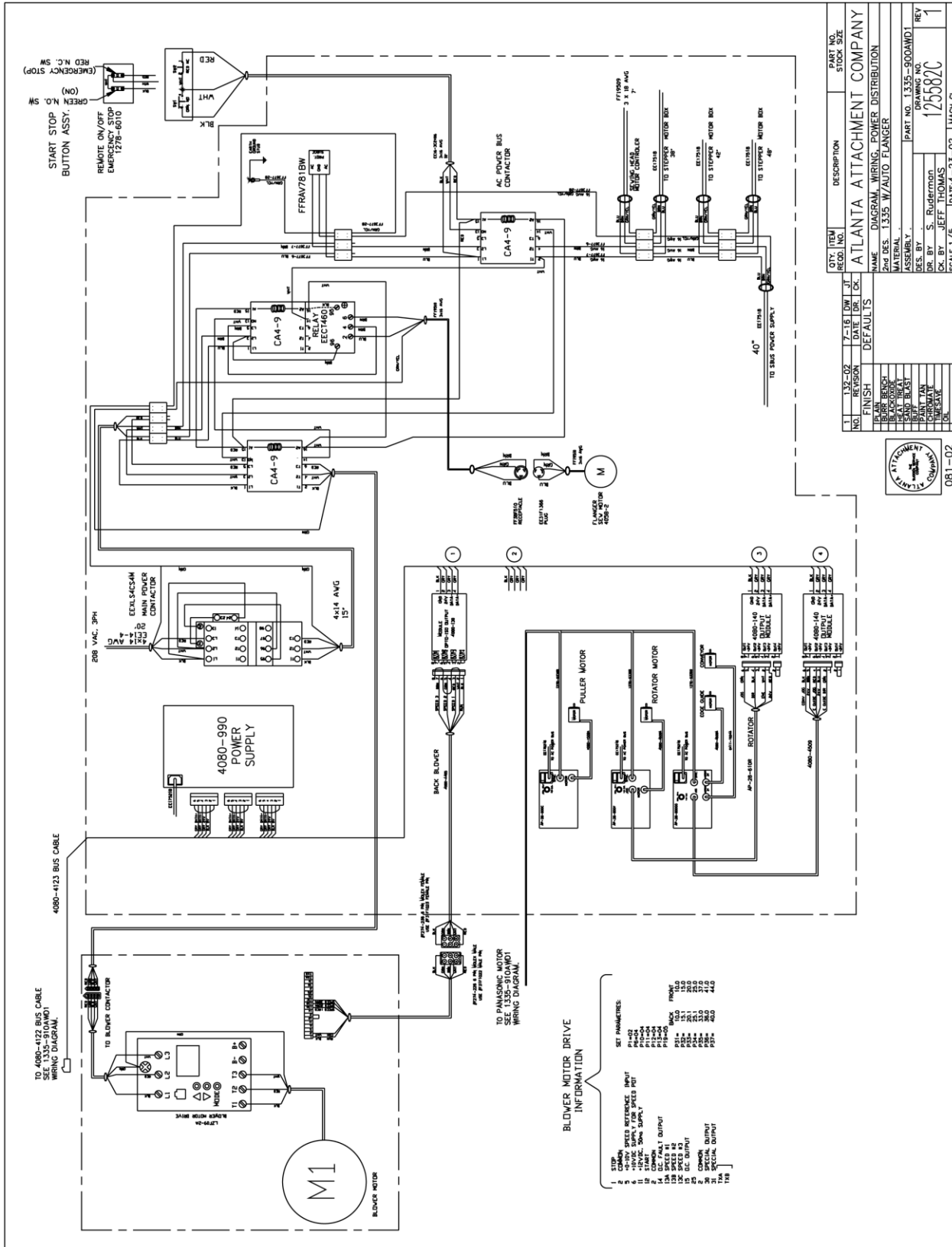

QTY	ITEM	DESCRIPTION	PART NO.	STOCK SIZE
1	1335-900	208 VAC 3PH		
1	REASON	DATE	BY	CHK
FINISH				
1	PLAN	DATE	BY	CHK
1	REASON	DATE	BY	CHK
MATERIAL				
ASSEMBLY				
DESIGN				
CHK BY				
DATE				
SCALE				
PART NO. 1335-900AWD1				
DRAWING NO. 125502C				
REV. 1				



081-02

**BLOWER MOTOR DRIVE INFORMATION**

SET PARAMETERS:

- 128 COMMON SENSE REFERENCE
- 129 4080-990 POWER SUPPLY
- 130 4080-140 ROTATOR MOTOR
- 131 4080-140 PULLER MOTOR
- 132 4080-140 ROTATOR MOTOR
- 133 4080-140 PULLER MOTOR
- 134 4080-140 ROTATOR MOTOR
- 135 4080-140 PULLER MOTOR
- 136 4080-140 ROTATOR MOTOR
- 137 4080-140 PULLER MOTOR
- 138 4080-140 ROTATOR MOTOR
- 139 4080-140 PULLER MOTOR
- 140 4080-140 ROTATOR MOTOR
- 141 4080-140 PULLER MOTOR
- 142 4080-140 ROTATOR MOTOR
- 143 4080-140 PULLER MOTOR
- 144 4080-140 ROTATOR MOTOR
- 145 4080-140 PULLER MOTOR
- 146 4080-140 ROTATOR MOTOR
- 147 4080-140 PULLER MOTOR
- 148 4080-140 ROTATOR MOTOR
- 149 4080-140 PULLER MOTOR
- 150 4080-140 ROTATOR MOTOR
- 151 4080-140 PULLER MOTOR
- 152 4080-140 ROTATOR MOTOR
- 153 4080-140 PULLER MOTOR
- 154 4080-140 ROTATOR MOTOR
- 155 4080-140 PULLER MOTOR
- 156 4080-140 ROTATOR MOTOR
- 157 4080-140 PULLER MOTOR
- 158 4080-140 ROTATOR MOTOR
- 159 4080-140 PULLER MOTOR
- 160 4080-140 ROTATOR MOTOR
- 161 4080-140 PULLER MOTOR
- 162 4080-140 ROTATOR MOTOR
- 163 4080-140 PULLER MOTOR
- 164 4080-140 ROTATOR MOTOR
- 165 4080-140 PULLER MOTOR
- 166 4080-140 ROTATOR MOTOR
- 167 4080-140 PULLER MOTOR
- 168 4080-140 ROTATOR MOTOR
- 169 4080-140 PULLER MOTOR
- 170 4080-140 ROTATOR MOTOR
- 171 4080-140 PULLER MOTOR
- 172 4080-140 ROTATOR MOTOR
- 173 4080-140 PULLER MOTOR
- 174 4080-140 ROTATOR MOTOR
- 175 4080-140 PULLER MOTOR
- 176 4080-140 ROTATOR MOTOR
- 177 4080-140 PULLER MOTOR
- 178 4080-140 ROTATOR MOTOR
- 179 4080-140 PULLER MOTOR
- 180 4080-140 ROTATOR MOTOR



# 1335Q-900AWD2 Wiring Diagram

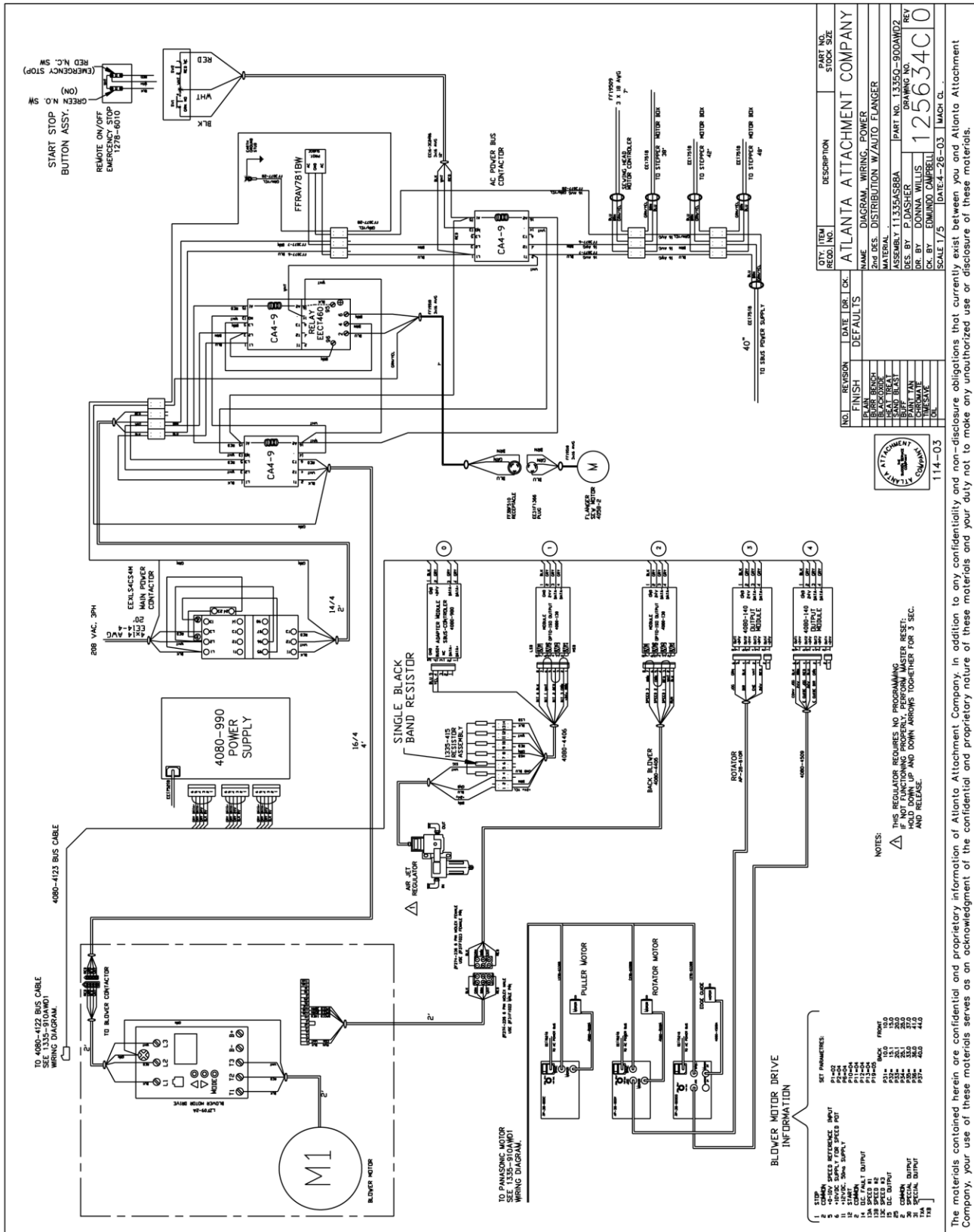

QTY	ITEM	DESCRIPTION	PART NO.	STOCK SIZE
			ATLANTA ATTACHMENT COMPANY	
			NAME: DIAGRAM, WIRING, POWER	
			2nd DES. DISTRIBUTION W/AUTO FLANGER	
			MATERIAL: ASSEMBLY 11335A588A [PART NO. 1335Q-900AWD2]	
			DES. BY: P. DASHNER [DRAWING NO. 125634C0]	
			DR. BY: DONNO CALBERT [REV]	
			CHK. BY: [REVISION]	
			SCALE: 1/2 [DATE: 4-26-03] [MACH. CL.]	

NO.	REVISION	DATE	BY	CHK.	DESCRIPTION
					DEFAULTS
					PLAN
					ISSUE
					REVISION
					DATE
					BY
					CHK.
					DESCRIPTION

NOTES:

- THIS REGULATOR REQUIRES NO PROGRAMMING.
- IF NOT FUNCTIONING PROPERLY, PERFORM MASTER RESET: HOLD DOWN UP AND DOWN ARROWS TOGETHER FOR 3 SEC. AND RELEASE.

The materials contained herein are confidential and proprietary information of Atlanta Attachment Company. In addition to any confidentiality and non-disclosure obligations that currently exist between you and Atlanta Attachment Company, your use of these materials serves as an acknowledgment of the confidential and proprietary nature of these materials and your duty not to make any unauthorized use or disclosure of these materials.





## Appendix A

### Finishing the Gusset

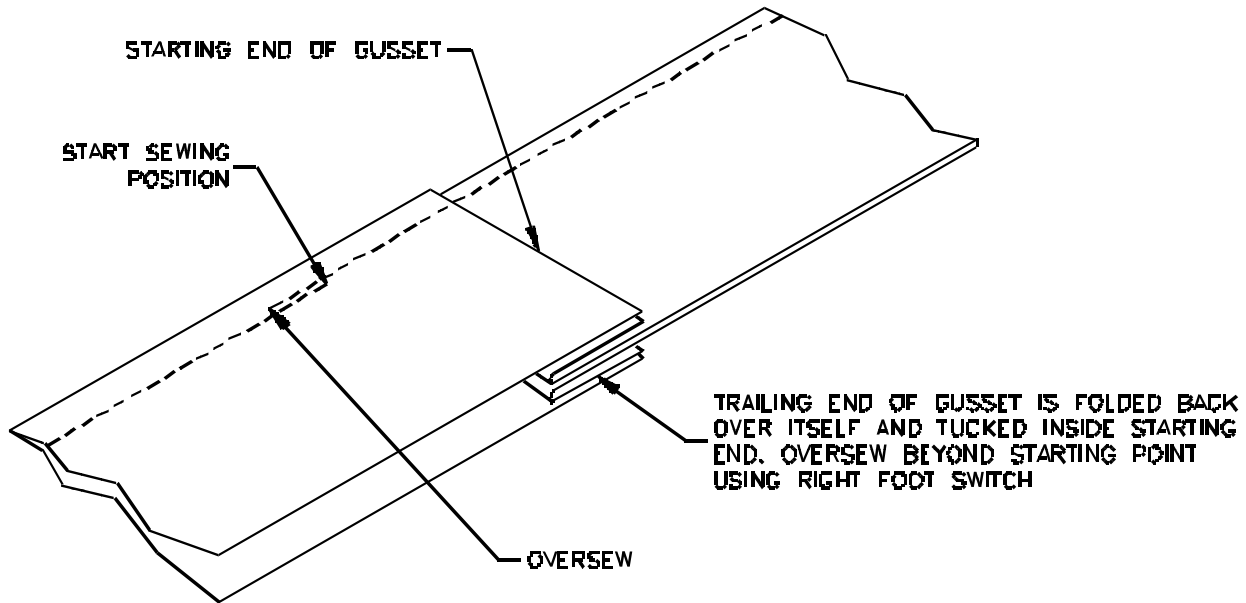

### Loading the Accumulator

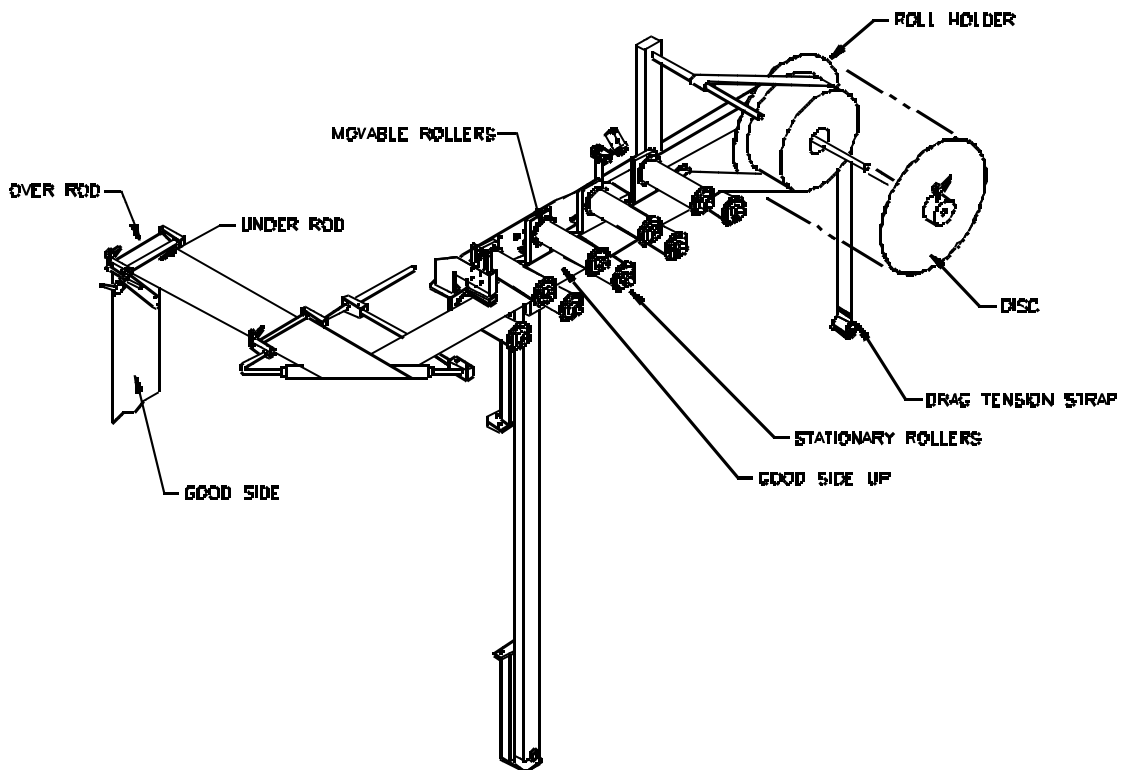

# Loading the Folder

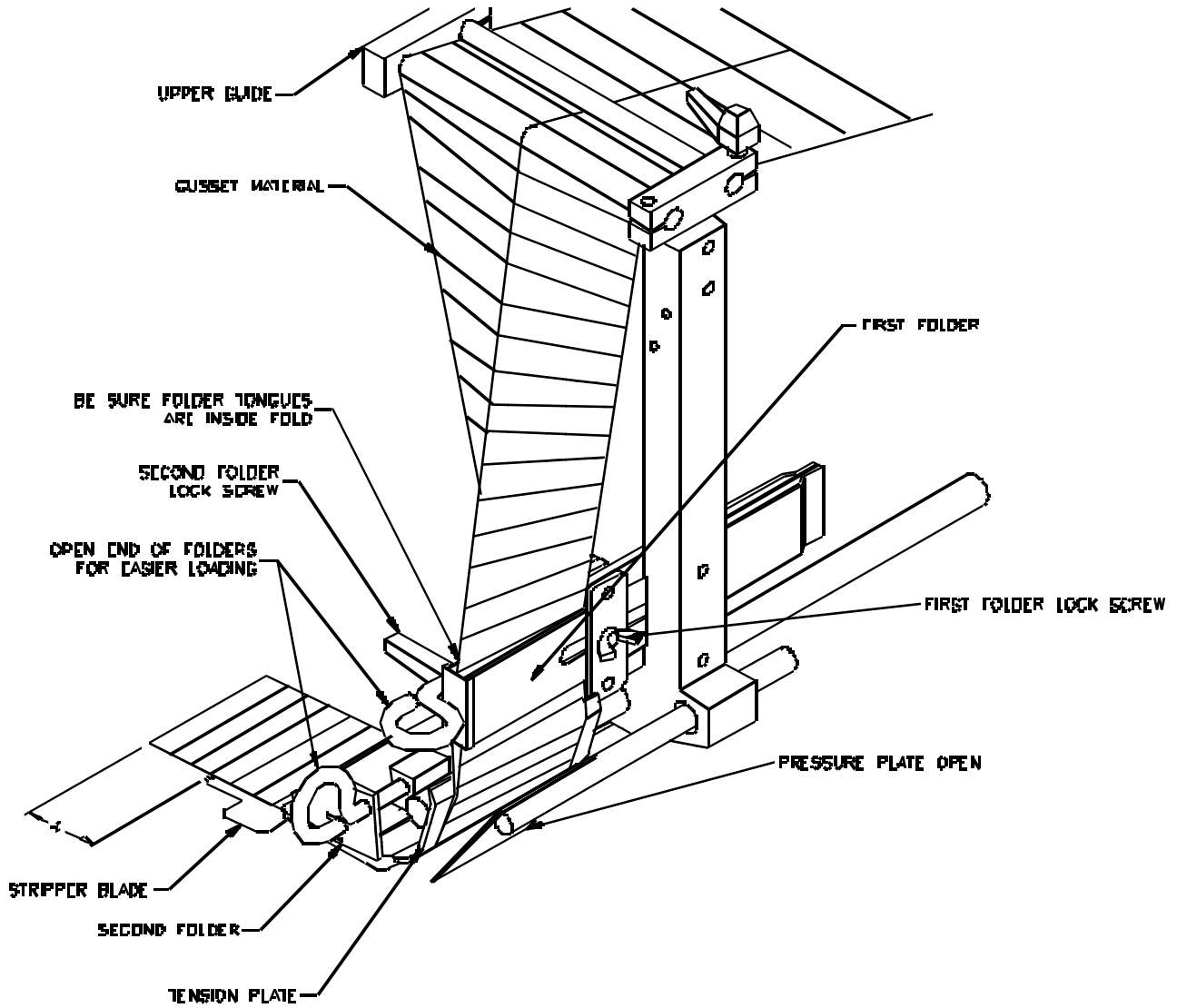



# Corner Ruffle

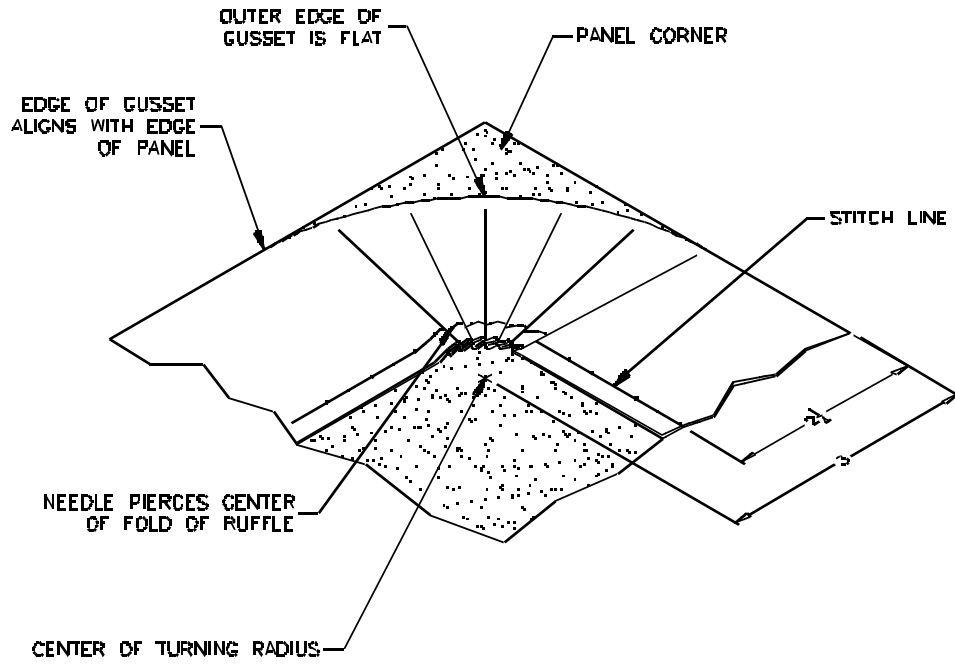

## Appendix B

# Accumulator

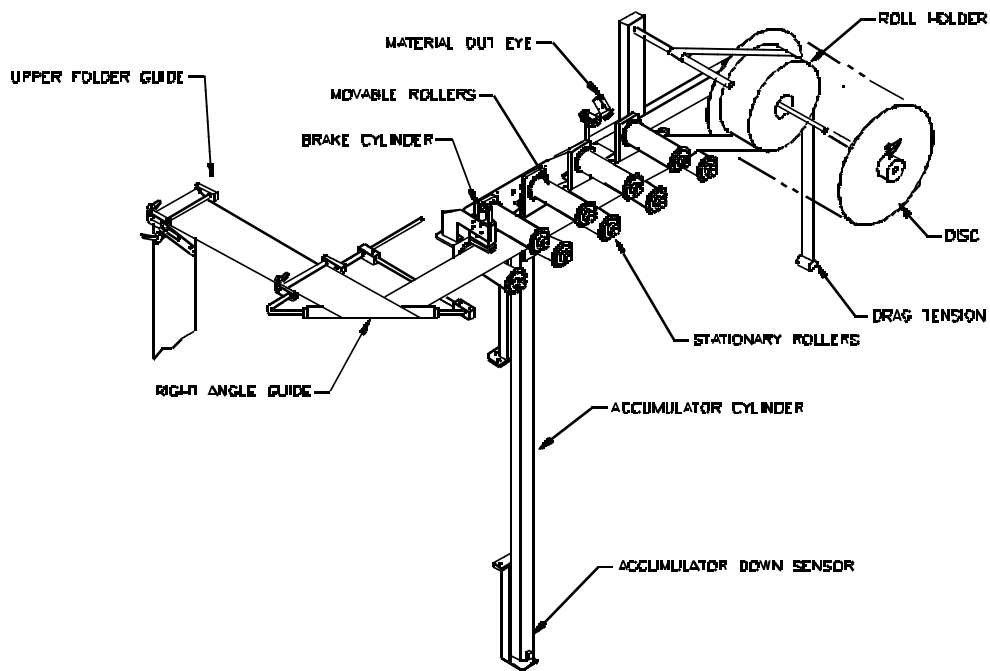

# Rear Conveyor

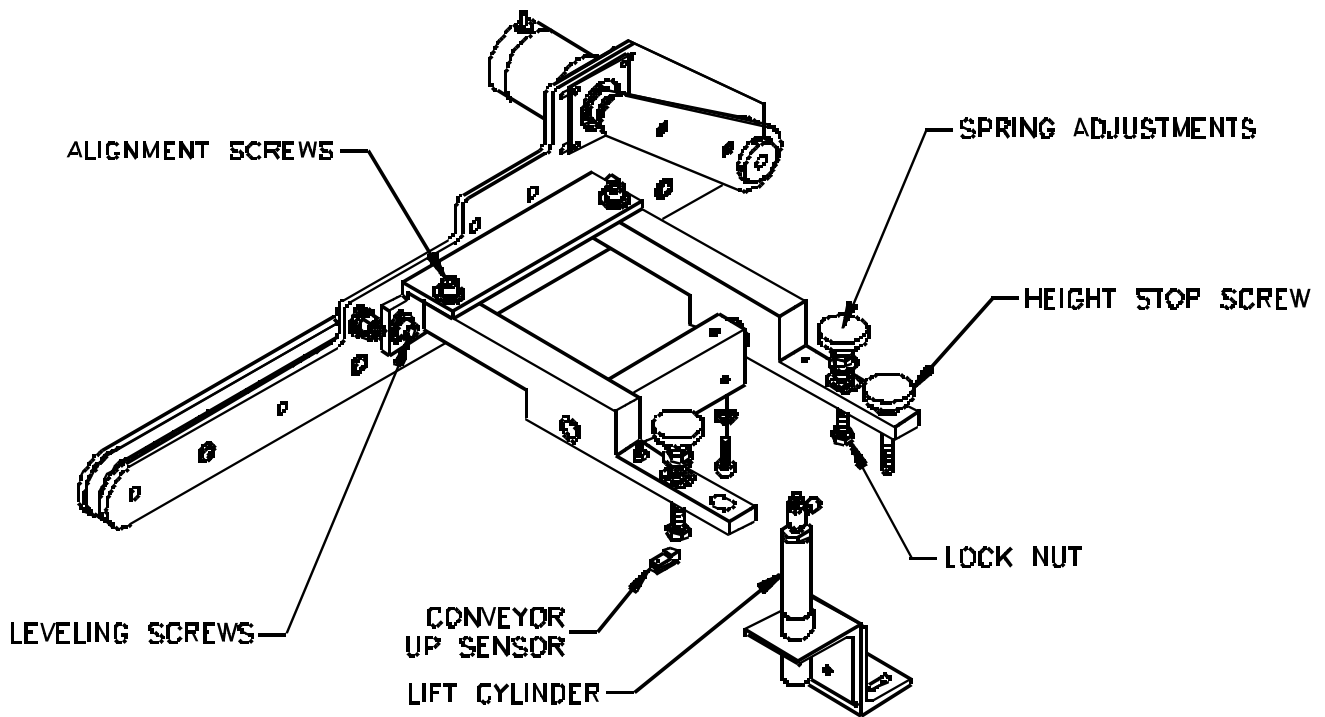

# Edge Guide

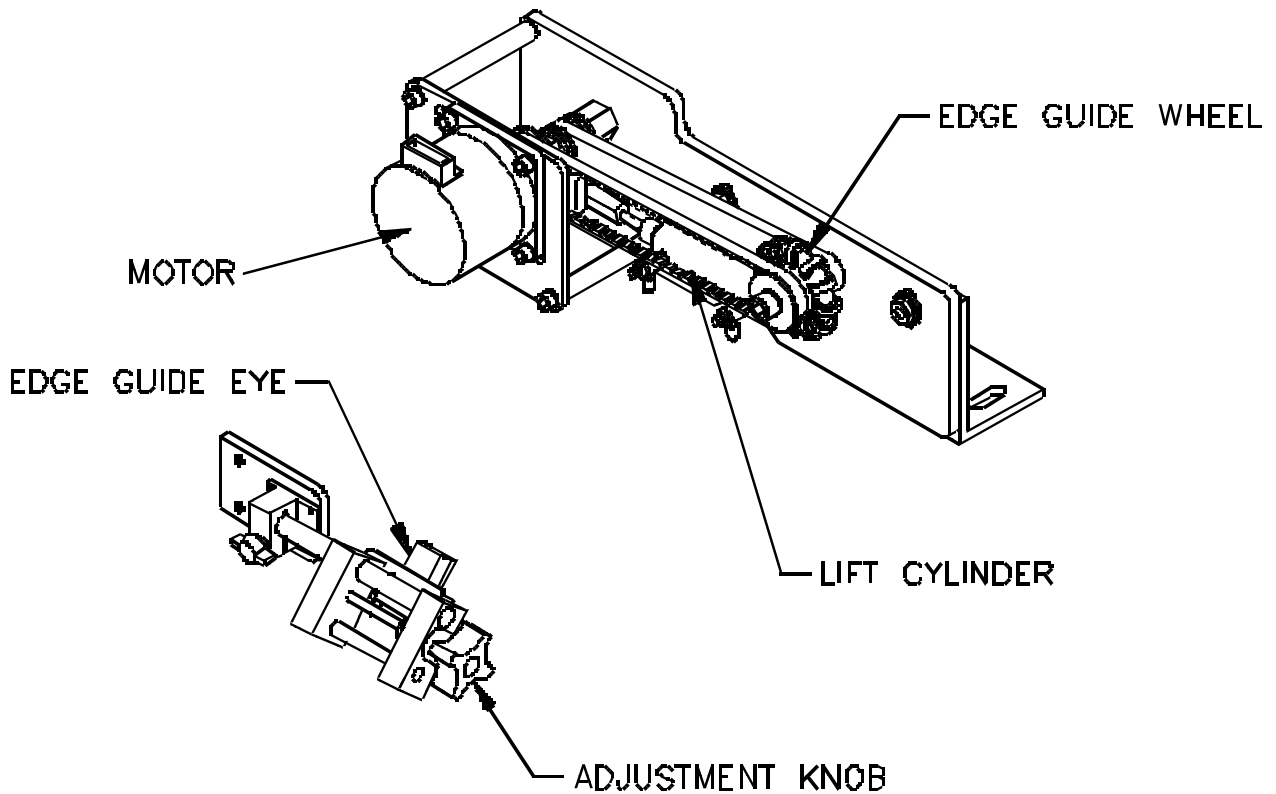

# Folder

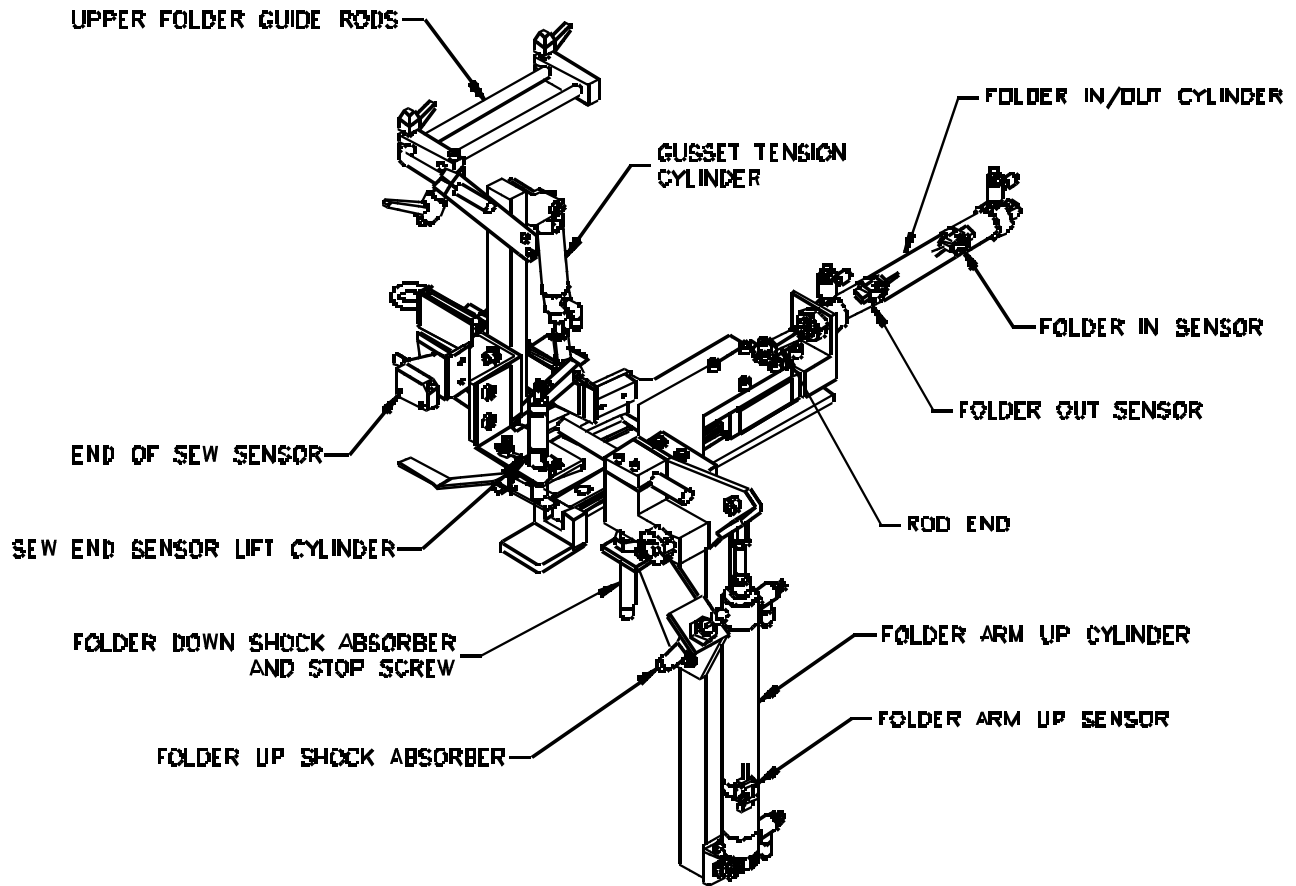

# Footlift

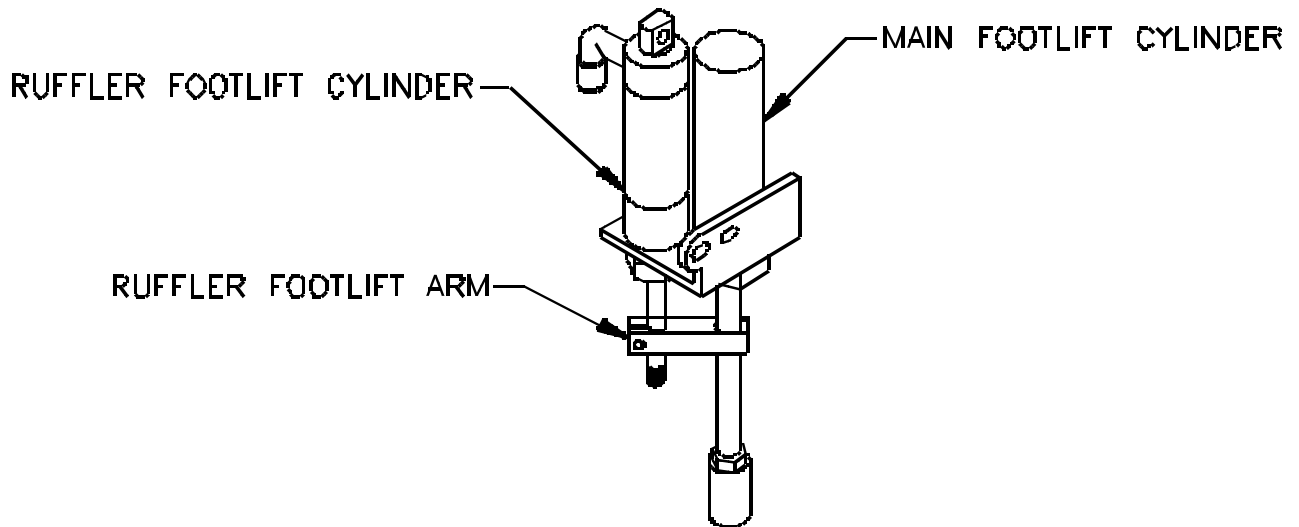

# Sewing Head

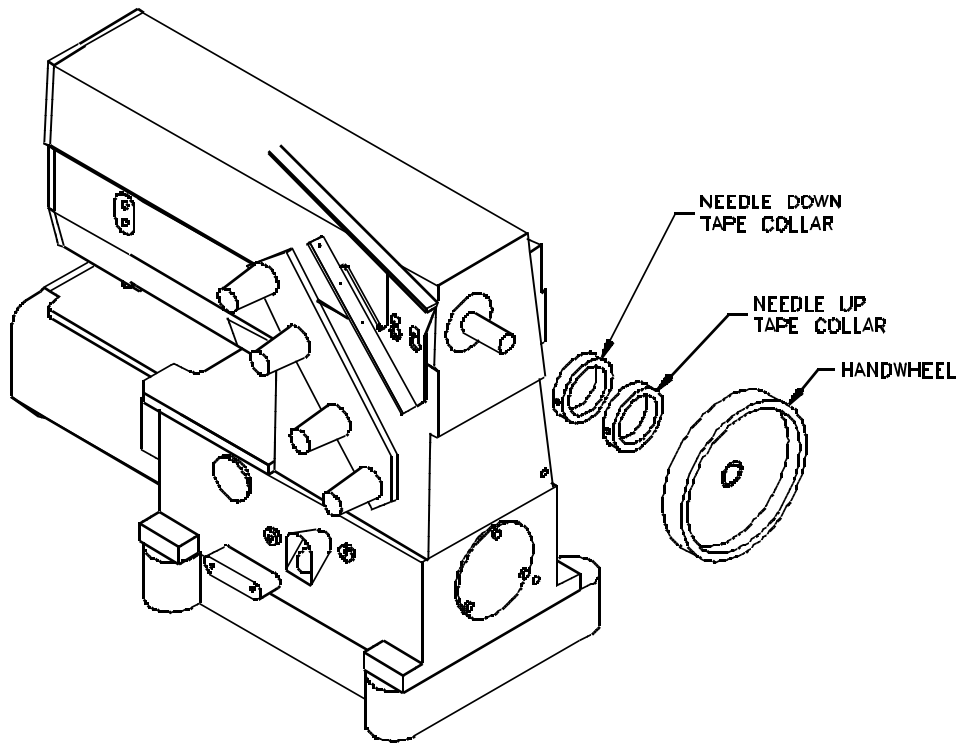

# Knife

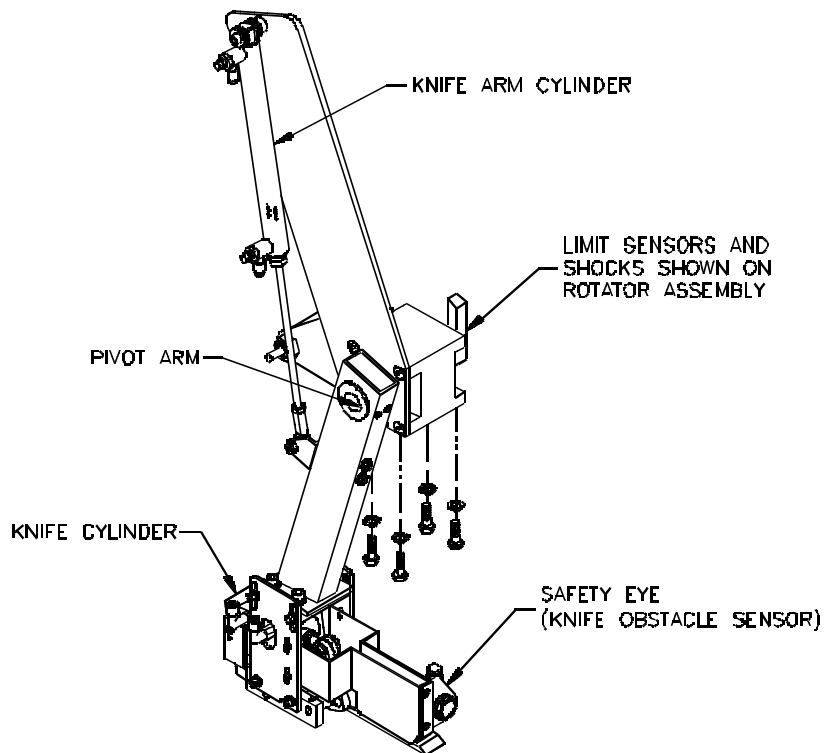

# Rotator

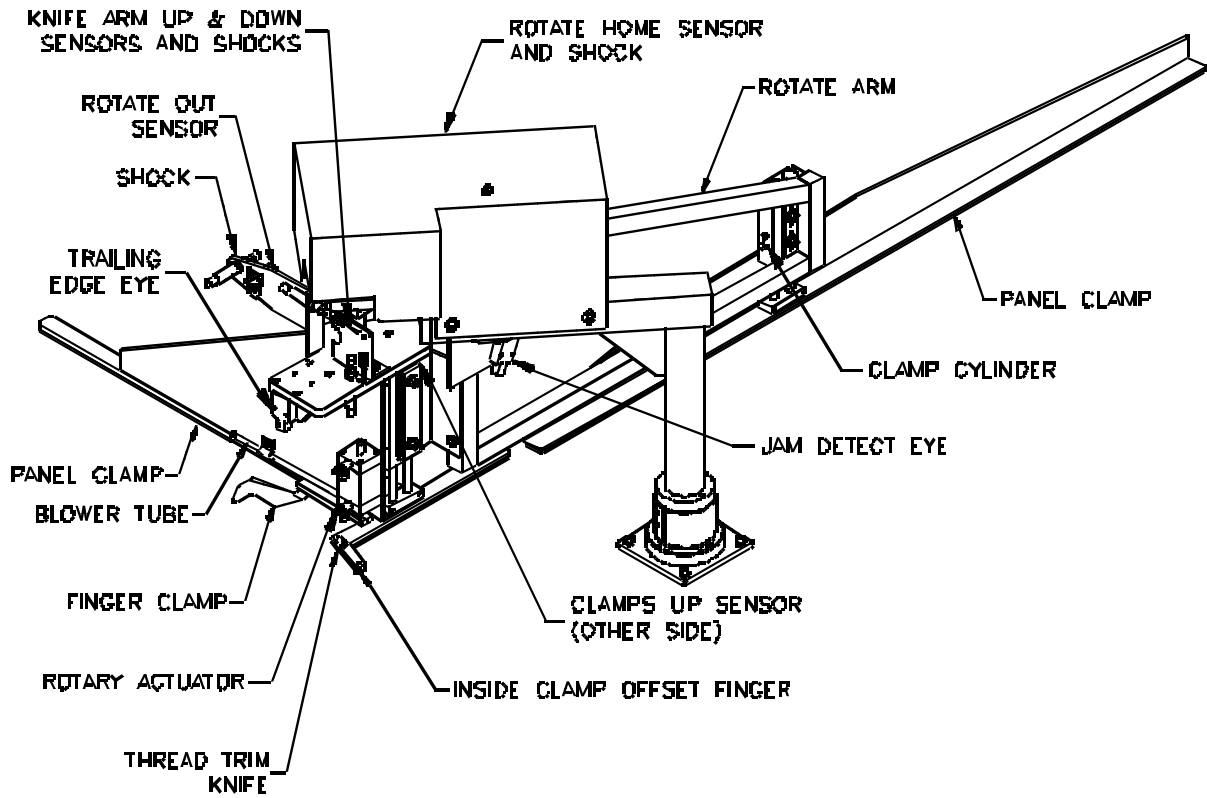

# Ruffler

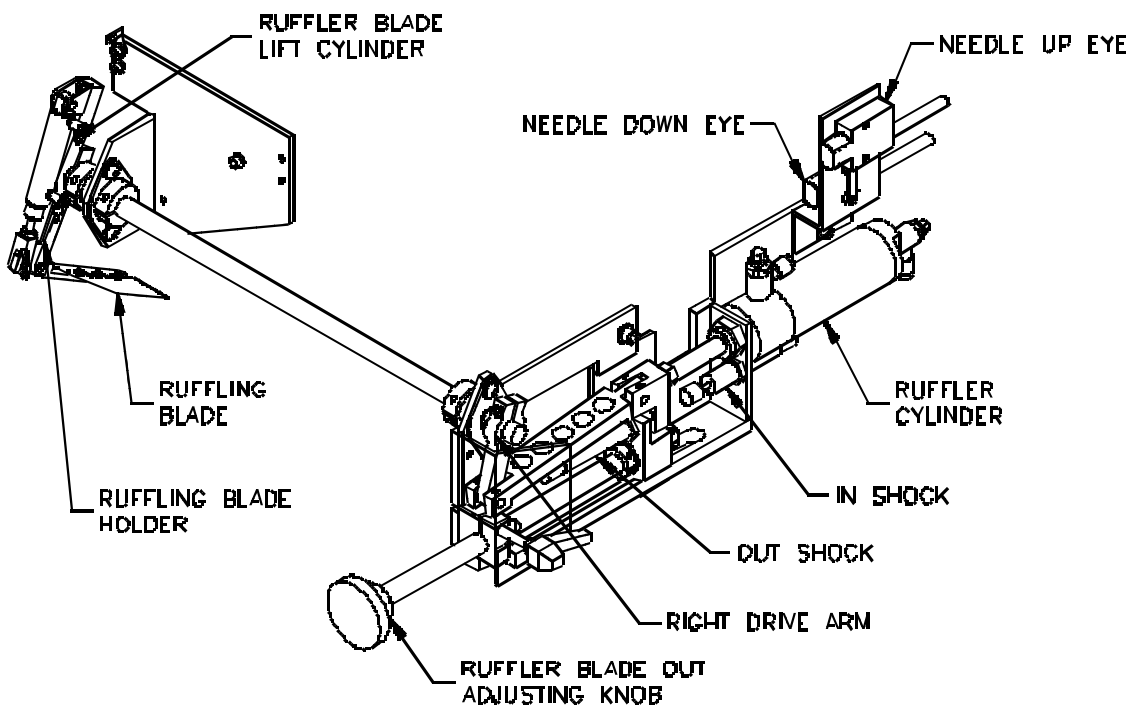

# Atlanta Attachment Company (AAC) Statement of Warranty

## Manufactured Products

Atlanta Attachment Company warrants manufactured products to be free from defects in material and workmanship for a period of eight hundred (800) hours of operation or one hundred (100) days whichever comes first. Atlanta Attachment Company warrants all electrical components of the Serial Bus System to be free from defects in material or workmanship for a period of thirty six (36) months.

## Terms and Conditions:

- AAC Limited Warranty becomes effective on the date of shipment.
- AAC Warranty claims may be made by telephone, letter, fax or e-mail. All verbal claims must be confirmed in writing.
- AAC reserves the right to require the return of all claimed defective parts with a completed warranty claim form.
- AAC will, at its option, repair or replace the defective machine and parts upon return to AAC.
- AAC reserves the right to make the final decision on all warranty coverage questions.
- AAC warranty periods as stated are for eight hundred (800) hours or one hundred (100) days whichever comes first.
- AAC guarantees satisfactory operation of the machines on the basis of generally accepted industry standards, contingent upon proper application, installation and maintenance.
- AAC Limited Warranty may not be changed or modified and is not subject to any other warranty expressed or implied by any other agent, dealer, or distributor unless approved in writing by AAC in advance of any claim being filed.

## What Is Covered

- Electrical components that are not included within the Serial Bus System that fail due to defects in material or workmanship, which are manufactured by AAC are covered for a period of eight hundred (800) hours.
- Mechanical parts or components that fail due to defects in material or workmanship, which are manufactured by AAC.
- Purchased items (sewing heads, motors, etc.) will be covered by the manufacturers (OEM) warranty.
- AAC will assist in the procurement and handling of the manufacturers (OEM) claim.

## What Is Not Covered

- Parts that fail due to improper usage, lack of proper maintenance, lubrication and/or modification.
- Damages caused by; improper freight handling, accidents, fire and issues resulting from unauthorized service and/or personnel, improper electrical, plumbing connections.
- Normal wear of machine and parts such as Conveyor belts, "O" rings, gauge parts, cutters, needles, etc.
- Machine adjustments related to sewing applications and/or general machine operation.
- Charges for field service.
- Loss of time, potential revenue, and/or profits.
- Personal injury and/or property damage resulting from the operation of this equipment.

# Declaración de Garantía

## Productos Manufacturados

Atlanta Attachment Company garantiza que los productos de fabricación son libres de defectos de material y de mano de obra durante un periodo de ochocientos (800) horas de operación o cien (100) días cual llegue primero. Atlanta Attachment Company garantiza que todos los componentes del Serial bus son libres de defectos de material y de mano de obra durante un periodo de treinta y seis (36) meses.

## Términos y Condiciones:

- La Garantía Limitada de AAC entra en efecto el día de transporte.
- Reclamos de la Garantía de AAC pueden ser realizados por teléfono, carta, fax o correo electrónico. Todo reclamo verbal tiene que ser confirmado vía escrito.
- AAC reserva el derecho para exigir el retorno de cada pieza defectuosa con un formulario de reclamo de garantía.
- AAC va, según su criterio, reparar o reemplazar las máquinas o piezas defectuosas devueltas para AAC.
- AAC reserva el derecho para tomar la decisión final sobre toda cuestión de garantía.
- Las garantías de AAC tiene una validez de ochocientas (800) horas o cien (100) días cual llega primero.
- AAC garantiza la operación satisfactoria de sus máquinas en base de las normas aceptadas de la industria siempre y cuando se instale use y mantenga de forma apropiada.
- La garantía de AAC no puede ser cambiado o modificado y no está sujeto a cualquier otra garantía implicado por otro agente o distribuidor menos al menos que sea autorizado por AAC antes de cualquier reclamo.

## Lo Que Está Garantizado

- Componentes eléctricos que no están incluidos dentro del sistema Serial Bus que fallen por defectos de materiales o de fabricación que han sido manufacturados por AAC son garantizados por un periodo de ochocientas (800) horas.
- Componentes mecánicos que fallen por defectos de materiales o de fabricación que han sido manufacturados por AAC son garantizados por un periodo de ochocientas (800) horas.
- Componentes comprados (Motores, Cabezales, ) son protegidos debajo de la garantía del fabricante.
- AAC asistirá con el manejo de todo reclamo de garantía bajo la garantía del fabricante.

## Lo Que No Está Garantizado

- Falla de repuestos al raíz de uso incorrecto, falta de mantenimiento, lubricación o modificación.
- Daños ocurridos a raíz de mal transporte, accidentes, incendios o cualquier daño como resultado de servicio por personas no autorizados o instalaciones incorrectas de conexiones eléctricas o neumáticas.
- Desgaste normal de piezas como correas, anillos de goma, cuchillas, agujas, etc.
- Ajustes de la máquina en relación a las aplicaciones de costura y/o la operación en general de la máquina.
- Gastos de Reparaciones fuera de las instalaciones de AAC
- Pérdida de tiempo, ingresos potenciales, y/o ganancias.
- Daños personales y/o daños a la propiedad como resultado de la operación de este equipo.



From the library of: Diamond Needle Corp

**Atlanta Attachment Company**  
362 Industrial Park Drive  
Lawrenceville, GA 30046  
770-963-7369  
[www.atlatt.com](http://www.atlatt.com)

**Printed in the USA**